

# STABILITY OF SMALL BARRIER ESTUARIES: FIRST PASS ASSESSMENT USING PUBLIC DATA AND ATTRACTOR MODELLING

Jon Hinwood<sup>1</sup> and Errol McLean<sup>2</sup>

Small barrier estuaries are common in temperate latitudes where catchment runoff is small. The entrance state controls the tidal exchange and hence the salinity regime and flushing. To aid the study and management of these estuaries, predictions of the stability and future evolution of the estuary entrance must be made. This paper demonstrates the application of the attractor method to determine the stability of a wide sample of estuaries on the south-eastern coast of Australia, using only data available in broad-based public data bases. The method uses a simple hydrodynamic-sediment balance model, run for thousands of scenarios and thousands of tide cycles to identify the long-term dynamic equilibria – the attractors. The model predictions are shown to match stability data in the data bases and to provide realistic predictions of the entrance evolution. The results have direct applicability to high-level assessment of coastal assets and to optimal selection of model scenarios for more detailed modelling of any selected estuary.

*Keywords: estuary; stability; ICOLL; attractor*

## INTRODUCTION

Intermittently open/closed barrier estuaries are found most frequently in temperate latitudes where catchment runoff is small, such as parts of the Spanish coast, South Africa and south-eastern Australia. These estuaries display a wide range of behaviors. To guide model scenario selection and to provide insight into their long-term evolution, a simple entrance stability model has been developed. The model results are in the form of the attractors that define the preferred states of the estuary entrance. The attractor map is a plot of the river flow vs entrance depth, showing the attractors. Public databases of estuary properties have been used to provide the data to run the model and so to obtain attractor maps for a representative set of estuaries on the New South Wales (NSW) coast of south-east Australia, ranging from tidal bays to tidal lagoons. The predictions of entrance stability from these attractor maps are compared with published field data.

In the next sections the attractor methodology is explained, the estuaries modelled are described and model results are tabulated. The discussion focusses on the probable long-term entrance regimes of each estuary and identifies the capabilities of using such public but limited data sets.

## ATTRACTOR METHODOLOGY

The attractors are found using a two-cell model of the hydrodynamics and sediment transport in the entrance constriction of the estuary, as described by Hinwood and Mclean (2015) and summarized in the Appendix. The model domain is shown in Fig. 1. The model results have been validated previously using an extensive data set (Hinwood, McLean 2014, 2015).

As averaged inflows and sediment supply are used, the effects of storms are not reproduced in detail, only as averaged changes in depth, so the method applied in this paper cannot be applied to very small estuaries where a single storm may cause closure (Thuy et al., 2013); time dependent studies have been done but require the model to be fully calibrated for each estuary.

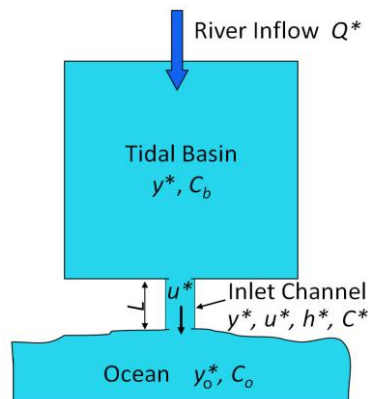

Figure 1. The model domain and key variables; the star denotes dimensional quantities, no star non-dimensional.

<sup>1</sup> Dept. Mechanical & Aerospace Engineering, Monash University, Clayton, Vic. 3800, Australia. [jbhinwood@gmail.com](mailto:jbhinwood@gmail.com)

<sup>2</sup> School of Earth, Atmospheric & Life Sciences, University of Wollongong, NSW 2522, Australia. [errol@uow.edu.au](mailto:errol@uow.edu.au)

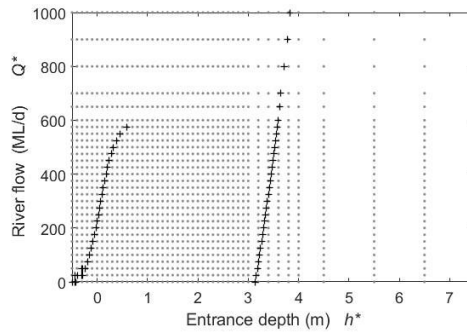

Figure 2. Attractor map for an estuary. Dots show starting conditions for each model run, crosses show end positions. Crosses are super-imposed along the two attractors.

The model is run until a dynamic equilibrium is attained, typically about 5,000 tide cycles, for 300 to 3000 scenarios, comprising sets of initial conditions of river flow,  $Q^*$ , and entrance depth,  $h0^*$  as shown by the regular array of dots in Fig. 2. The final value of  $h^*$  for each run is plotted against  $Q^*$ . The points cluster in lines that are the attractors, depicting the states to which the estuary evolves under the assumed conditions of tide, river flow and coastal sediment supply, as shown in Fig. 2. Fig. 2 shows two attractors for flows  $Q^* < 600$  ML/d, with one continuing to greater discharges. We have called the deeper attractor on the right the Tidal Attractor because tidal action is dominant in causing both scour and supply of marine sediment to the entrance channel. The shallower attractor on the left we have called the River Flow Attractor. Again, the tidal flow is the dominant process causing scour and inflow of marine sediment, but here the river flow biases the velocities in the entrance channel and enhances the scour. Without this biasing the entrance would rapidly accrete and close. The River Flow Attractor has depths close to zero relative to MWL in the ocean and hence is vulnerable to fluctuations in river flow, and the effects of storms on sediment supply and ocean water level.

Fig. 3 shows the attractor map schematically. The arrows show the pattern of depth changes over time, arrows pointing right indicating scour and to the left indicating deposition in the inlet channel. The Watershed is an unstable equilibrium separating the catchments of the two attractors and had been identified by Escoffier as an unstable equilibrium. The flow  $Q_s$  is the maximum for which there is a River Flow Attractor, and the intersection of  $Q_s$  and the Tidal Attractor defines the critical depth  $h_s$ . The region defined by  $Q^* \leq Q_s$  and  $h^* \leq h_s$  includes zones that are shoaling, others that are scouring but we consider this whole zone to be vulnerable to natural fluctuation of flow, water level and sediment transport. We have used the terms ‘stability flow’ and ‘stability depth’ for  $Q_s$  and  $h_s$  in following sections.

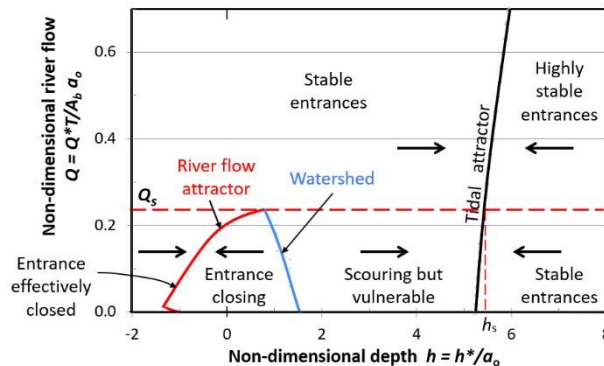

Figure 3 –The two attractors and entrance stability within each zone

The Tidal Attractor matches a generalization of O’Brien’s prism-area formula and Escoffier’s stable equilibrium, with the significant improvement that the Tidal Attractor is based on the time-integrated sediment transport and not on one selected velocity (Hinwood and McLean, 2018). The River Flow Attractor is an observed stable, but vulnerable, state that is additional to those recognized in other simple models.

Estuaries with flows and depths close to the Watershed will scour or shoal as river flow and other conditions fluctuate, moving the estuary across the watershed and making the estuary behavior

intermittent. Estuaries with high entrance resistance or sediment supply tend to have a Merged Attractor with only the River Flow Attractor at low flows ( $Q^* < Q_s^*$ ) and only the Tidal Attractor at high flows ( $Q^* > Q_s^*$ ). The merged attractor estuaries will change behavior as the river flow fluctuates, moving up or down across the merged attractor.

## SELECTED ESTUARIES AND DATA

### Choice of Data Base

The focus of the research is on the smaller estuaries of the south-east coast of Australia, in particular the coast of NSW. This fact and the data requirements of the model guided the search and selection of the data base used. There are about half a dozen data bases with a fair coverage of the NSW coast with an overlap of variables listed but some useful differences. Of these, two stand out, firstly the OzEstuaries (2010) data base is the most authoritative and provides the most complete coverage of estuaries and coastal data. It was developed in the year 2000, based on the older Australian Estuarine Database and other estuarine datasets at that time. Since then the site has been continually upgraded and the scope expanded to consider all aspects of the coast under the title of OzEstuaries. The other key data base with almost complete coverage of the small estuaries is Roper(2011). Both OzEstuaries and Roper provide data on location, water area, estuary geomorphic type, catchment inflows and ocean tide. The OzEstuaries data base provides extensive data on the presence and areas of different estuarine geomorphic zones and substrates while Roper provides data on the estuarine tide and entrance condition that are essential for the present research. For these reasons we have selected the Roper data base as our primary source, cross checking against OzEstuaries

Of the other data bases we reviewed, the Haines (2006) data base provided confirmatory dimensions for some estuaries and the quantitative stability measure ‘% time entrance closed’ used here. The Roy (2001) data base filled some gaps in Roper (2000) and included information on the stage of geomorphic evolution of the estuaries that could be used to strengthen the prediction of future estuary evolution. The Hanslow et al (2008) paper is focussed on the berm and, for a small number of estuaries, it provides data on berm height, beach dimensions, and surface sediment properties that would be valuable for shorter term modelling of entrance breakout. The DPIE (2020) has an on-line data base, accessible by the public on an estuary by estuary basis. This data base has a complete coverage of NSW estuaries and includes a brief description and a low altitude aerial photograph of each estuary. A valuable check but not as convenient for searching and tabulating as the above sources.

### Selected Estuaries

Table 1. Estuary areas and types			
Estuary	Water area km <sup>2</sup>	Estuary Type (Roper)	Entrance Type (Roper)
Lake Brou	2.37	Lg	I
Currambene Creek	2.22	Br	O
Durras Lake	3.60	Lg	I
Khappinghat Creek	1.03	Lg	I
Macleay River	27.39	Br	O/T
Minnamurra River	1.53	R	O
Narrawallee River	0.86	R	O(I)
Port Jackson	45.59	B	O
Port Kembla	2.53	B	O
Smiths Creek	10.01	L	I
Lake Tabourie	1.45	Lg	O(I)
Tomaga River	1.35	Br	O
Lake Wollumboola	6.33	L	I

Estuary Type : L=lake; Lg=lagoon; Br=barrier river; B=bay; R=river

Entrance Type: O=open; T=trained; I=intermittent; normally closed

The 10 estuaries have been selected from the comprehensive data base of estuaries in NSW, in Roper et al (2011), to include all major types from tidal bays to intermittently closed/open lakes and lagoons (ICOLLs). Some additional data used in model runs have been obtained from the inventories in OzEstuaries (2010) and Haines (2006) and from Google Earth. The estuaries are listed in Table 1. An alternative measure of entrance stability is the ‘% time entrance is closed’, provided in the data base of Haines (2006). Tables 2 and 3 below show that this measure is consistent with Roper’s Estuary Type

In a typical case study of an estuary, all data required to run the model will be obtained from site-specific studies. On the other hand, for high-level assessment, as envisaged in the present paper, key data would be obtained from public data bases. Specific model inputs that were obtained from the data bases are the estuary water surface area, the entrance channel breadth and length, the ocean tidal amplitude and the catchment inflows to the estuary. The hydraulic resistance and sediment pick-up parameters used were textbook values for typical marine sediments (silica sand 0.2mm diameter).

## MODEL RESULTS

Model runs to produce attractor maps were made of all estuaries, with the inflows and initial depths extending well beyond the observed conditions in order to ensure that the attractors had been located. For many estuaries, long runs of 10,000 tide cycles were required to achieve final convergence, although the patterns were clear from early in any run. From the attractor maps the attractor types were identified and  $Q_s^*$  and  $h_s^*$  evaluated, these quantities are discussed in the next section. All estuaries showed a River Flow Attractor at shallow depths and small catchment inflows, and a Tidal Attractor at higher discharges and depths. These attractor patterns have been reported previously only for barrier estuaries (Hinwood, McLean 2015). Estuaries with separate and merged attractors were found, with the latter more often having higher entrance hydraulic resistance.

Durras Lake was typical of the estuaries found to have separate Tidal and River Flow Attractors at lower flows, as shown in Fig. 4. In Figure 2a, each of the small crosses indicates the starting conditions for a model run, while the larger + signs denote the end points, which are the attractors. Durras Lake is an ICOLL that is normally open. Figure 2b shows contours of change in bed elevation; the colour scale has been chosen to show the watershed and attractors.

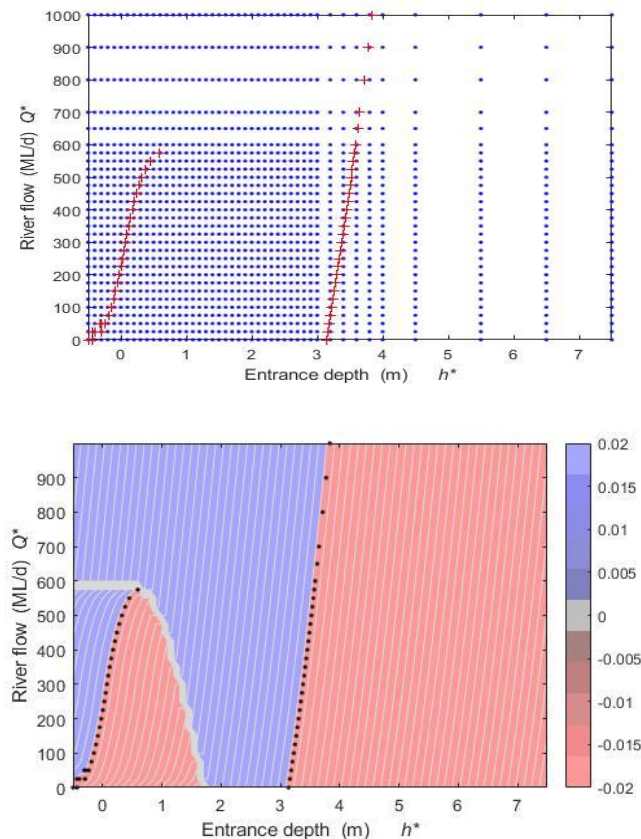

Figure. 4. Attractor Maps showing separate attractors for Durras Lake, a) Start and end points of model runs, b) Contours of change in bed elevation over model simulation of 10,000 tides

The attractor map in Fig. 5, for the Tomaga R estuary, is typical of the merged attractor, with only the River Flow Attractor for  $Q^* < 550\text{ML/d}$  and only the Tidal Attractor present for  $Q^* > 550\text{ML/d}$ .

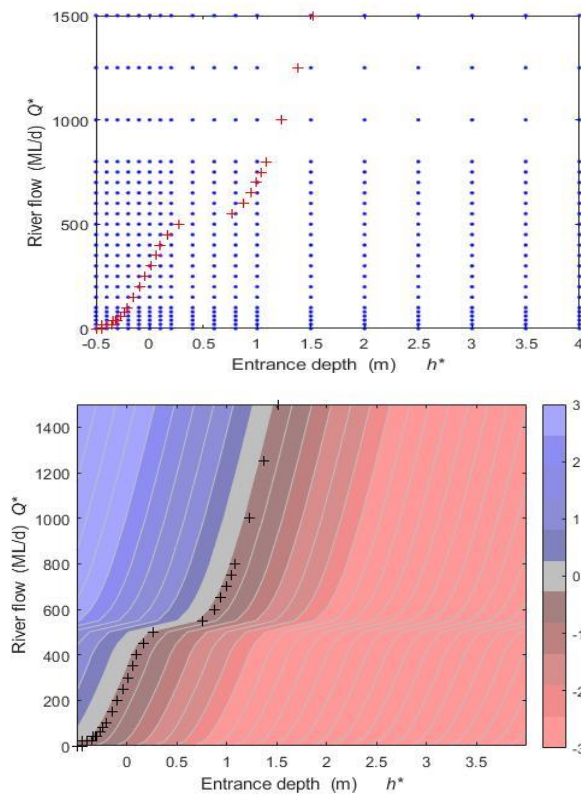

Figure 5. Attractor Maps of Tomaga River estuary showing merged attractors a) Start and end points of model runs, b) Contours of change in bed elevation over model simulation of 5,000 tides

**DISCUSSION**

To compare the model results with field observations, we have reviewed the classification data in the different data bases and the literature. A fundamental classification for the smaller, usually intermittent estuaries is the split between normally open and normally closed entrances (Cooper, 2001; Haines, 2006; Hinwood and McLean, 2015). Model results are compared with field data for normally open entrances in Table 2 and for normally closed entrances in Table 3. Within each table, the estuary classification of Roper has been used to group geomorphically similar estuaries.

Table 2 Model and field data: normally open entrances					
Estuary Class & Name	Entrance Condition Roper	% time closed Haines	Attractor type model	$Qm/Qs$ model	$H/Hs$ model
Bay					
Pt Jackson	O	0	M	>0.01	0.73
Pt Kembla	O	0	M	0.13	65.16
River					
Minnamurra	O	n/a	S	0.40	2.79
Narrawallee	O/I	1	SM	0.27	2.92
Barrier River					
Currambene	O	n/a	M	0.18	1.06
Macleay R	O/T	n/a	M	2.13	1.60
Tomaga R	O	n/a	M	0.13	1.88

$H = h + a_0$  = depth referred to HW. barrierR = barrier river; O/T = open/training wall. n/a = not available

The final two columns in each table relate the nominal present state of the entrance to the stability discharge, below which there is a River Flow Attractor, and the stability depth,  $h_s^*$  (Fig. 3). Because  $h^*$ , the present depth below ocean MWL (mean water level), is negative in some cases,  $H^*$ , the depth below ocean MHW (mean high water) has been used in the tables.

From the data in Table 2, despite some gaps, it is clear that Roper's open (O) entrance condition is consistent with Haines' % time closed, having a value near zero.

Of the two bays, the  $Q_m/Q_s$  values show that both bays have median inflows less than the stability flow. In addition, Port Kembla has  $H/H_s > 1$  and, with the low inflow and merged attractor, means that it is expected to be slowly shoaling. Port Jackson has  $H/H_s < 1$  and is expected to be shoaling. While this appears to be in conflict with its observed stability, it is shoaling. Harris et al. (2019) found that the maximum bedrock depth at the entrance in the drowned river channel was 85m but this was overlain by up to 65m of sediment, primarily Holocene marine sand.

The two rivers have inflow below the stability flow but depth greater than stability depth. Minnamurra has separate attractors and the present depth is greater than the Tidal Attractor depth, hence it is shoaling towards the Tidal Attractor. The Tidal Attractor, a stable state, is consistent with the entrance condition O. Narrawallee has a merged attractor at the median discharge so, on average, is slowly accreting and in the long term is unstable, consistent with the entrance condition O(I).

All three barrier rivers have  $H/H_s > 1$  but Currumbene Creek and the Tomaga River are predicted to be slowly shoaling on average. As episodic floods are likely to scour the entrance, the slow shoaling is unlikely to cause frequent closures, so that the entrances would rarely be closed. In particular, the trained entrance of the Macleay is likely to be more stable than this analysis shows as it has been observed by the authors that the presence of one or both training walls increases stability – as noted by Weigel (1965).

Thus the attractor analysis has correctly identified the three estuary classes with normally open entrances and provides guidance on their future evolution and management.

Table 3, normally closed entrances, has the same format as Table 2. As the descriptions of the estuary classes 'lake' and 'lagoon' appear to differ largely in size and constriction of the water body, we have chosen to combine them under the heading 'lagoon'.

Five of the six estuaries in this class have entrances classified as intermittent (I). This consistent classification differs from all three of the normally open estuary classes. Haines' % closure data support the description 'normally closed'. Tabourie is an outlier with entrance condition O(I) but its closure 70% of the time fits normally closed. The majority of these estuaries have separate, S, attractors, again distinct from the predominantly open types. All six have median flow less than stability flow, in fact  $Q_m/Q_s < 0.2$  for the 4 estuaries with S type attractors. All of these estuaries except Tabourie have depth less than stability depth, with the four having  $H/H_s < 0.1$ . Thus we expect all but Tabourie to be closed or rapidly closing.

Estuary	Entrance	% time	Attractor	$Q_m/Q_s$	$H/H_s$
Class & Name	Condition	closed	type		
	Roper	Haines	model	model	model
Lake					
Smiths L & Ck	I	80	S	0.18	0.04
Lagoon					
Brou L	I	97	S	0.13	0.07
Durras L	I	62	S	0.09	0.02
Khappinghat	I	n/a	M	0.70	0.15
Tabourie L	O(I)	70	M	0.05	1.21
Wollumboola L	I	96	S	0.09	0.03

From the present study, Tabourie appears to be intermediate between the normally open and normally closed, but verging on the latter. Tabourie has  $H/H_s = 1.21$ , within the slow shoaling zone, so like the barrier rivers it will be open a significant part of the time.

The model results have application to the design of a barrier breach to reopen a closed entrance. To create a self-maintaining channel requires a depth within the catchment of the Tidal Attractor. As the attractor map shows, this is roughly half the stability depth. The design may be optimized by creating attractor maps for several entrance breadths. For this group of estuaries, the two with merged attractors would not have a stable depth but would tend to close, although slowly.

Another application is in the design of environmental flow releases, in which some of the water diverted from a river is returned to the river and estuary in controlled releases. One of the design criteria for some environmental flow releases is to scour excess sediment from river or estuary channels. The attractor map shows the flows required to create a stable channel of any specified depth. In the case of the 4 estuaries with separate attractors, a minimum depth must be created before the release to position the estuary in the catchment of the Tidal Attractor, as shown on the attractor map.

The attractor analysis has identified 'lakes and lagoons' as a distinct type, has shown that they are likely to be closed or rapidly closing, and has correctly identified Tabourie as an outlier that is likely to be slow to close once opened.

## CONCLUSIONS

The attractor analysis, using a simple hydrodynamic and sedimentation model, has shown that a wide range of estuary types possess the two attractors, previously found for barrier estuaries. Each attractor corresponds to a dynamically stable state. The deeper Tidal Attractor corresponds to the O'Brien prism-area relation, while the much shallower River Flow Attractor would be stable under constant conditions but is vulnerable to closure due to natural variability. The present position of an estuary on the attractor map allows its stability and likely future evolution to be determined. The Attractor Map allows the stability of a dredged or artificial entrance to be estimated, conditions for self-maintaining channel depths to be estimated, and provides a quick and simple guide to selection of scenarios for more sophisticated modelling.

The simplifications inherent in any one or two-cell model, restrict its use to providing a "high level", long-term guide, suitable for rapid screening of options or for identifying the optimum set of scenarios for more comprehensive study. Use of these models to obtain time of responses, such as closure or scour depth, require site-specific calibration to tune the values of lumped parameters.

## REFERENCES

- Cooper, J.A.G. (2001). Geomorphological variability among microtidal estuaries from the wave-dominated South African coast. *Geomorphology* 40, 99–122.
- DPIE (2020) Estuaries of New South Wales NSW Department of Planning, Industry and Environment. <https://www.environment.nsw.gov.au/topics/water/estuaries/estuaries-of-nsw/tabourie-lake> Last accessed 6/11/2020.
- Hager, W.H., (2005). Du Boys and sediment transport, *Journal of Hydraulic Research* 43(3), 227-233.
- Haines, P.E. (2006) *Physical and Chemical Behaviour and Management of Intermittently Closed and Open Lakes and Lagoons (ICOLLs) in NSW*, PhD thesis, Griffith University, Qld, Australia.
- Hanslow, D.J., Davis, G.A., You, B.Z. and J. Zastawny (2008) Berm height at coastal lagoon entrances in NSW, *10th Annual NSW Coastal Management Conf.*, Yamba, NSW, Australia. 12pp.
- Hinwood, J.B. and E.J.McLean (2014). Entrance changes in the Snowy River estuary in response to environmental flow releases. *Australian Journal of Civil Engineering*, 12(1), 16-29.
- Hinwood, J.B. and E.J.McLean (2015). Predicting the dynamics of intermittently closed/open estuaries using attractors, *Coastal Engineering*, 99, 64-72.
- Hinwood, J.B. and E.J.McLean (2018). Tidal inlets and estuaries: Comparison of Bruun, Escoffier, O'Brien and attractors, *Coastal Engineering*, 33: 92-105.
- OzEstuaries (2010) A module of *OzEstuaries* (in preparation but currently as a stand-alone module), Geoscience Australia and CSIRO, Commonwealth Government, Canberra., Australia. <http://www.ozcoasts.org.au/> last accessed November 2020.
- Roper, T., Creese, B., Scanes, P., Stephens, K., Williams, R., Dela-Cruz, J., Coade, G., Coates, B. and Fraser M. (2011). *Assessing the condition of estuaries and coastal lake ecosystems in NSW*, Monitoring, evaluation and reporting program, Technical report series, Office of Environment and Heritage, Sydney, Australia.

Roy P. S., Williams, R.J., Jones, A.R., Yassini, I., Gibbs, P.J., Coates, B., West" R.J., Scanes, P.R., Hudson, J.P. and S. Nichol (2001). Structure and function of South-east Australian Estuaries, *Estuarine, Coastal and Shelf Science*, 53, 351–384

Thuy, T. T. V., P. Nielsen & D. P. Callaghan (2013): Inferring inlet morphodynamics and hydraulic parameters from tidal records: A case study of four closure events of Avoca Lake Australia. *Int J Earth Sciences & Eng*, Vol 6 No 2, pp 225-231.

Wiegel, R.L. 1965. *Oceanographical Engineering*, Prentice-Hall, Englewood Cliffs, New Jersey, p381.

#### APPENDIX: THE MODEL

The HydSed model uses the one-dimensional mass conservation equation, Eq.(1), and momentum conservation equation, Eq.(2), to evaluate the entrance velocity,  $u^*$  (flood direction positive) and the water elevation in the estuary relative to the mean water level (MWL) in the ocean,  $y^*$ . It treats the estuary as a single cell and the entrance channel as another cell as shown in Fig.1.

$$A_b \frac{dy^*}{dt^*} = -B(y^* + h^*)u^* + Q^* \quad (1)$$

$$\frac{\partial u^*}{\partial t^*} = -\frac{f}{8} \frac{u^* |u^*|}{(h^* + y^*)} - (y_o^* - y^*) \frac{g}{L} - \frac{K}{2L} u^* |u^*| \quad (2)$$

where  $A_b$  is the water area of the estuary,  $t^*$  is time,  $B$  is the entrance channel breadth,  $h^*$  the depth of the entrance channel below MWL,  $Q^*$  the river inflow,  $f$  the bed friction coefficient,  $y_o^*$  the ocean tide level,  $g$  gravity and  $K$  the entrance channel form resistance.

This form of the one-dimensional hydrodynamic equations is an improvement on the usual simplified equations in that the entrance depth changes as both ocean and estuary depth change, so the model can reproduce the principal effects of fluvial inflows, tidal forcing and Reynolds number.

HydSed uses a one-dimensional sediment pick-up equation, Eq.(3) and a sediment balance equation, Eq.(4), to determine deposition or scour in the inlet channel and hence to determine its depth. Eq.(3) uses an approximation to the du Boys formula, (Hager, 2005).

$$C^* = m \left( \left( \frac{u^*}{u_c} \right)^2 - 1 \right) \quad (3)$$

$$L \frac{\partial h^*}{\partial t^*} = (y^* + h^*) u^* \Delta C^* \quad (4)$$

where  $C^*$  is the sediment concentration of the water in the channel,  $m$  is an empirical constant,  $u_c$  the threshold velocity for both pick up and deposition,  $C_o$  is the sediment concentration of the ocean,  $C_b$  that of the basin and

$$\begin{aligned} \Delta C^* &= C_o - C^* && \text{for flood} \\ \Delta C^* &= C^* - C_b && \text{for ebb} \end{aligned}$$

The equations have been written in non-dimensional form then solved in the time domain using a fast semi-implicit finite difference scheme in Mathworks MATLAB (Hinwood and McLean, 2015).