

Chapter 14

THEORETICAL FORMS OF SHORELINES

by

W. Grijm

Engineer Coastal Research Department Rijkswaterstaat

SUMMARY

Laboratory tests say that the littoral transport by waves reaches a maximum value when the waves approach the shore obliquely. In some way this must lead to peculiarities in the forms of shorelines. Therefore we put the question what types of shorelines can mathematically exist assuming the littoral transport is ruled by the function $\sin 2\alpha$ where α is the angle between the wave front and the shoreline. This yields some basic types of shorelines. After a brief discription of the mathematical treatment these results will be discussed.

This paper is a continuation of the paper presented on the same subject at the 7th conference on coastal engineering.

INTRODUCTION

The configuration of sandy shores and the changes in it depends completely on the variation in the transport of sand above the seabottom. The sand movement is a consequence of the movement of the water. In its turn the watermovement is a result of the tide and of the wind action. For the coastal engineer it is of importance to know the relations between the stream and wave characteristics on the one side and the intensity of the littoral sand transport on the other side. Therefore several laboratory tests have been made to get an idea about these relations. Knowing how extremely complicated these relations are we have to expect much scatter in the results of these tests. In spite of this scatter however all tests show a similar characteristic. They say that the intensity of the littoral transport is maximum when the waves approach the shore obliquely. Some tests say that this maximum is reached

when the angle α between the wave front and the shoreline is 30° . Other tests say that this happens when this angle is 60° . Whatever the real value may be it seems to be true that the intensity of the littoral transport has a maximum by a value of α which differs much from $\alpha = 0^\circ$ and from $\alpha = 90^\circ$.

On the supposition that this fact must lead to certain peculiarities in the form of shorelines the coastal research department of the Rijkswaterstaat in the Netherlands has made a study about this. They have put the question what types of shorelines can mathematically exist assuming the littoral transport is ruled by the function $\sin 2\alpha$ which has its maximum value when $\alpha = 45^\circ$.

THE MATHEMATICAL TREATMENT

Considering a stretch of shore of an infinite small length we have the condition that the quantity of deposited (or eroded) material must be equal to the difference between the quantities transported by the sea at the beginning and at the end of that stretch of shore. On the basis of figure 1 we put:

$$\frac{\partial q}{\partial \varphi} d\varphi dt = ar d\varphi \frac{\partial r}{\partial t} dt$$

or

$$\frac{\partial q}{\partial \varphi} = ar \frac{\partial r}{\partial t}$$

in which

r and φ are the polar coordinates of the considered point of the shore
 q is the function that determines the quantity of the littoral transport
 t is the time

a is the depth of the water which will be a function of r and φ

The magnitude of q depends on the angle α only. So this angle holds a key position. Therefore we take α as the independent variable instead of φ . This has two consequences. First the form of the equation of continuity must be reduced to:

$$\frac{\partial q}{\partial \alpha} + ar \left(\frac{\partial r}{\partial \alpha} \frac{\partial \varphi}{\partial t} - \frac{\partial r}{\partial t} \frac{\partial \varphi}{\partial \alpha} \right) = 0 \quad (1)$$

Secondly we need another equation to relate α and φ . On the basis of figure 2 we have:

$$\alpha + \varphi + \psi = \beta \quad (2)$$

It will be clear that β defines the direction of the wind. But ψ is a new variable also depending on α and t . So we cannot get away from

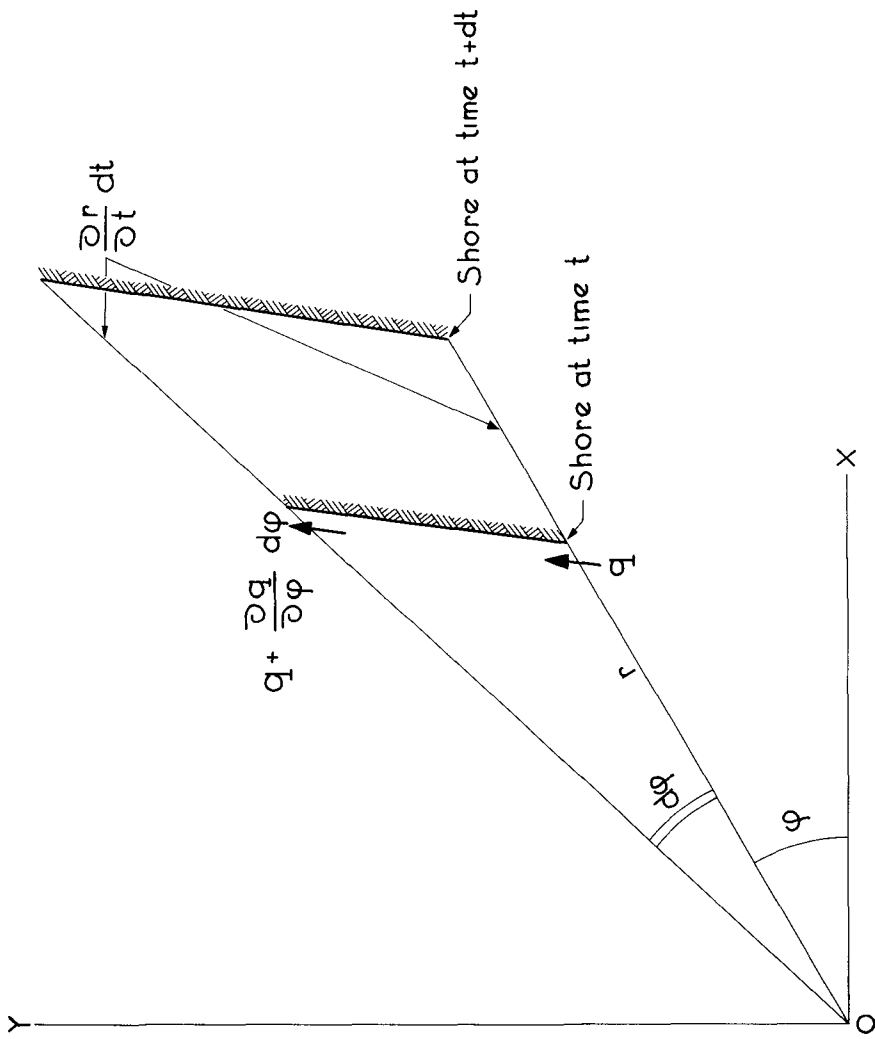

FIGURE 1

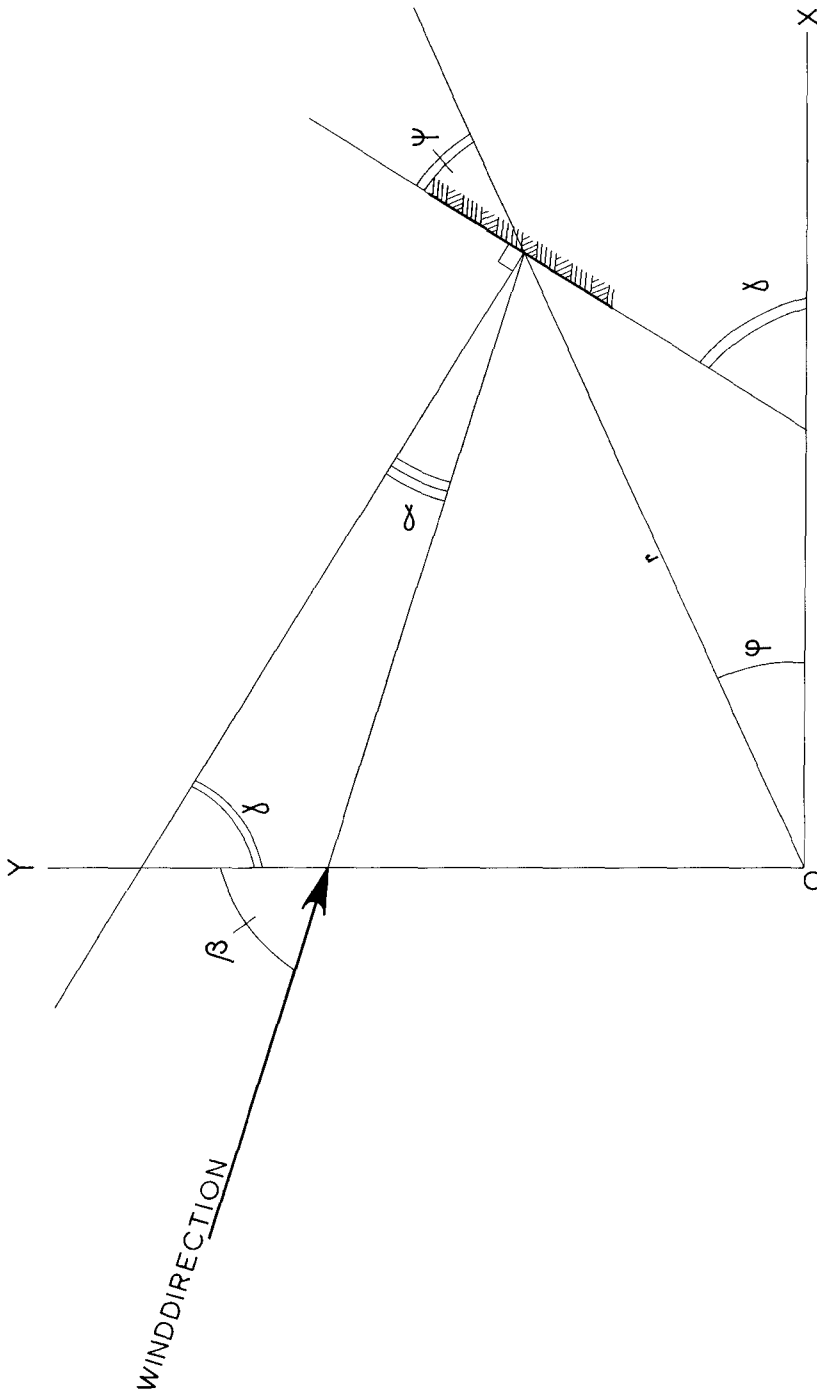

FIGURE 2

another equation that defines ψ . From the well-known formula:

$$\tan \psi = \frac{r}{r'}$$

we derive:

$$\tan \psi \frac{\partial r}{\partial \alpha} = r \frac{\partial \varphi}{\partial \alpha} \quad (3)$$

Now the problem is to find functions which satisfy the three equations (1), (2) and (3). We shall try whether the following combination of functions will do.

$$\begin{aligned} a &= c r^n \phi(\varphi) \\ r &= R(\alpha) T(t) \\ \varphi &= \varphi(\alpha) \\ q &= A Q(\alpha) \end{aligned}$$

where Q , φ and R are functions of α only and T is only a function of the time t .

Substituting these functions in the equation of continuity (1) yields:

$$\frac{\frac{dQ}{d\alpha}}{R^{n+2} \phi \frac{d\varphi}{d\alpha}} = \frac{c}{A} \cdot T^{n+1} \frac{dT}{dt}$$

On the left hand side of this equation there are expressions of α only, on the right hand side there appears only the time t . This equation can only be satisfied when both parts are equal to a constant k . This yields the two conditions:

$$\begin{aligned} dQ &= k R^{n+2} \phi d\varphi \\ T^{n+1} dT &= \frac{kA}{c} dt \end{aligned} \quad (4)$$

The second condition offers no problem while it can be integrated to:

$$T = \sqrt[n+2]{(n+2) \frac{kA}{c} (t - t_0)} \quad (5)$$

where t_0 is an integration constant. The first condition replaces the original equation of continuity (1). However much simpler we are not able to solve the set of equations (2), (3) and (4) unless we restrict ourselves further. Therefore we assume that the bottom of the sea is horizontal. This means that $n = 0$ and that $\phi = 1$.

Finally we have obtained the following set of equations we can manage:

$$dQ = k R \cdot d\varphi \quad (6)$$

$$\tan \psi dR = R \cdot d\varphi \quad (7)$$

$$\alpha + \varphi + \psi = \beta \quad (8)$$

while the function T is:

$$T = \sqrt{\frac{2kA}{c} (t - t_0)}$$

The function Q can have each form. We took for it the function $\sin 2\alpha$. It is useful to realise that the chosen combination of functions shows a certain character. The matter is that when we divide the radius vector r by T we obtain a value depending on α only. That means that the shoreline at the time $t = t_1$ and the shoreline at the time $t = t_2$ can be reduced to the very same shape by geometrical multiplying out of the origin. So to discuss these shorelines it is sufficient to discuss the curves given by R and φ which satisfy the equations (6), (7) and (8). The constant k can have each value. We took it equal to $\frac{1}{2}$ because then the relation of the area between two radius vectors in the graph of R with the area between the corresponding lines in the prototype is the most simple one.

THE RESULTS

Before discussing the solutions of these equations obtained by means of a computer we shall bring to the fore some general remarks on these solutions. First with respect to the function of $\sin 2\alpha$ it can be proved that when the curve a of figure 3 is a solution of the differential equation, the curves b, c and d will also satisfy the equations. Curves a and b and the curves c and d are symmetrical with respect to the wind direction. Curves a and c and the curves b and d are symmetrical with respect to the polar axis.

The second remarkable thing is that straight lines through the origin satisfy the equations but other straight lines do not.

The third point is that only in the octants 0, 3, 4 and 7 of figure 4^a these straight lines can be asymptotes of the solutions. This means that we can have bays and capes of a shape as shown in figure 4^b and 4^c, but when the angle δ becomes more than 45° the bays and capes must be shaped as in the figures 4^d and 4^e while in the points A the condition of continuity must be satisfied. The fourth point which asks attention is the fact that when the littoral transport reaches its maximum value the shore line shows a cusp as will be shown later.

Figure 5 shows the result of a calculation on the computer. The computer was programmed to follow this curve starting from a point A practically in the infinite and stopping in another point B likewise in the in-

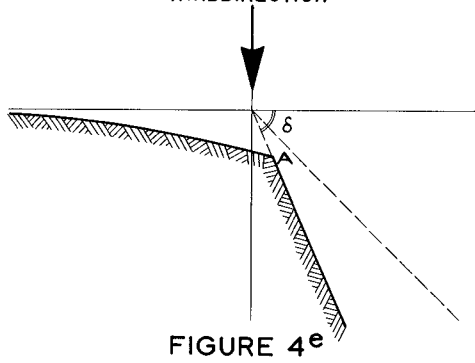
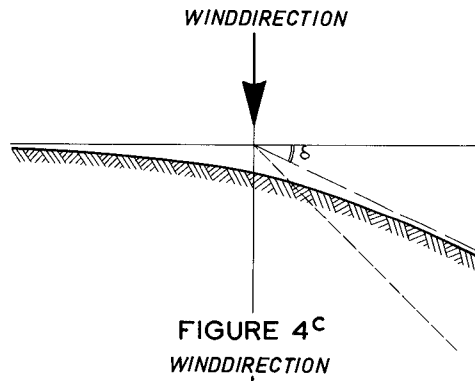
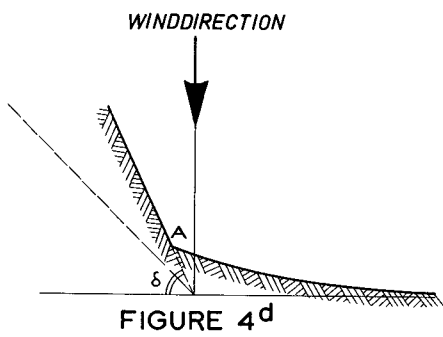
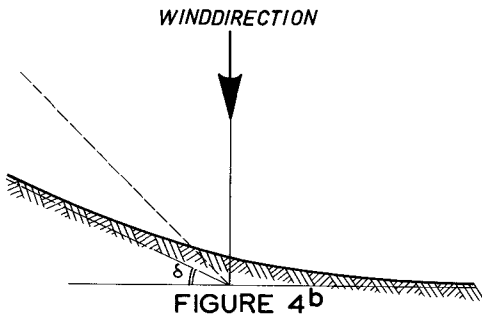
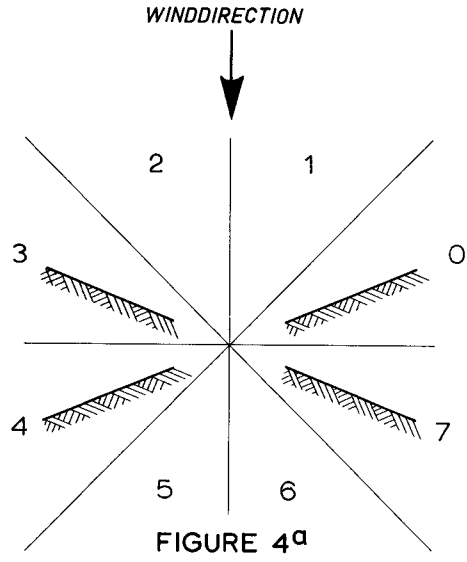
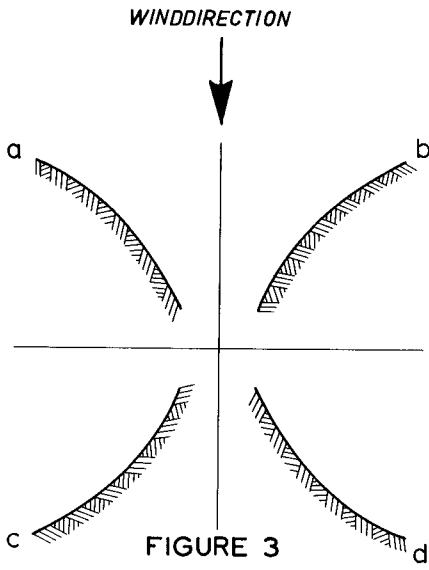

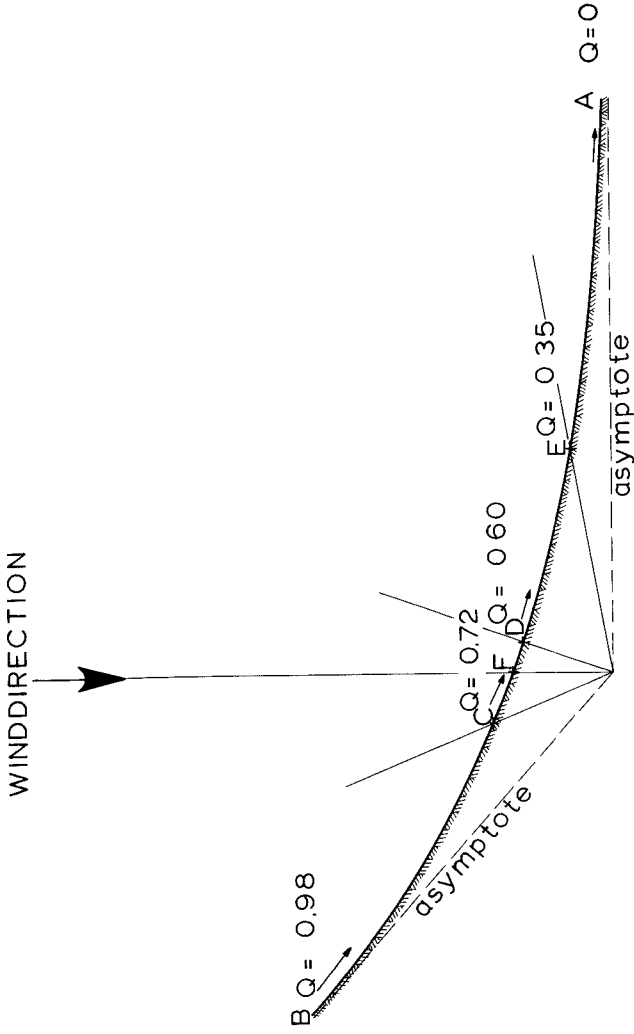

FIGURE 5

finite.

With this one solution of the differential equations we can construct shorelines of different types. First the curve of figure 5 can be interpreted as the shoreline of a bay or by mirroring with respect to the polar axis as the shoreline of a cape. Besides we can construct with this curve a symmetrical simple delta. Therefore we take only part A-F, mirror it with respect to the wind direction and put a rivermouth in point F. Then the condition is that the river brings a quantity of material to the sea that equals twice the quantity of the littoral transport in point F of the original curve.

But there is still a third way to use this curve. The computer has been programmed in such a way that all points of transition were indicated. A point of transition means that in that point the littoral transport along the curve has the same magnitude as the littoral transport that would take place when the shore would be situated along the radius vector to that point. In the curve of figure 5 there are three of such points C, D and E. At each point there is written down a number. This number gives the ratio between the magnitude of the littoral transport in that point and the quantity of material that the sea is able to transport. The magnitude of the littoral transport will be always expressed in this manner. With point C we can construct four other shorelines. This is not possible with the points D and E. Finally figure 6 shows all the shorelines which can be constructed from the curve of figure 5.

Mathematically there exists another shape of the shoreline for a symmetrical simple delta. This shape is shown in figure 7. The centre of curvature lies at the other side of the shore shown in figure 6. The curve links up the original shore in the finite and just in the point where the littoral transport equals zero.

It is easy to construct deltas with more rivermouths. The only thing we have to do is to link up different curves and to put a rivermouth in each point of connection. There the river must bring to the sea such a quantity of material that the condition of continuity is satisfied. Such composed deltas are shown in figure 8. A mathematical condition in constructing such deltas is that the river arms must be situated along a radius vector. These deltas are still symmetrical ones. It is also very simple to construct non-symmetrical deltas in the same way. The only thing

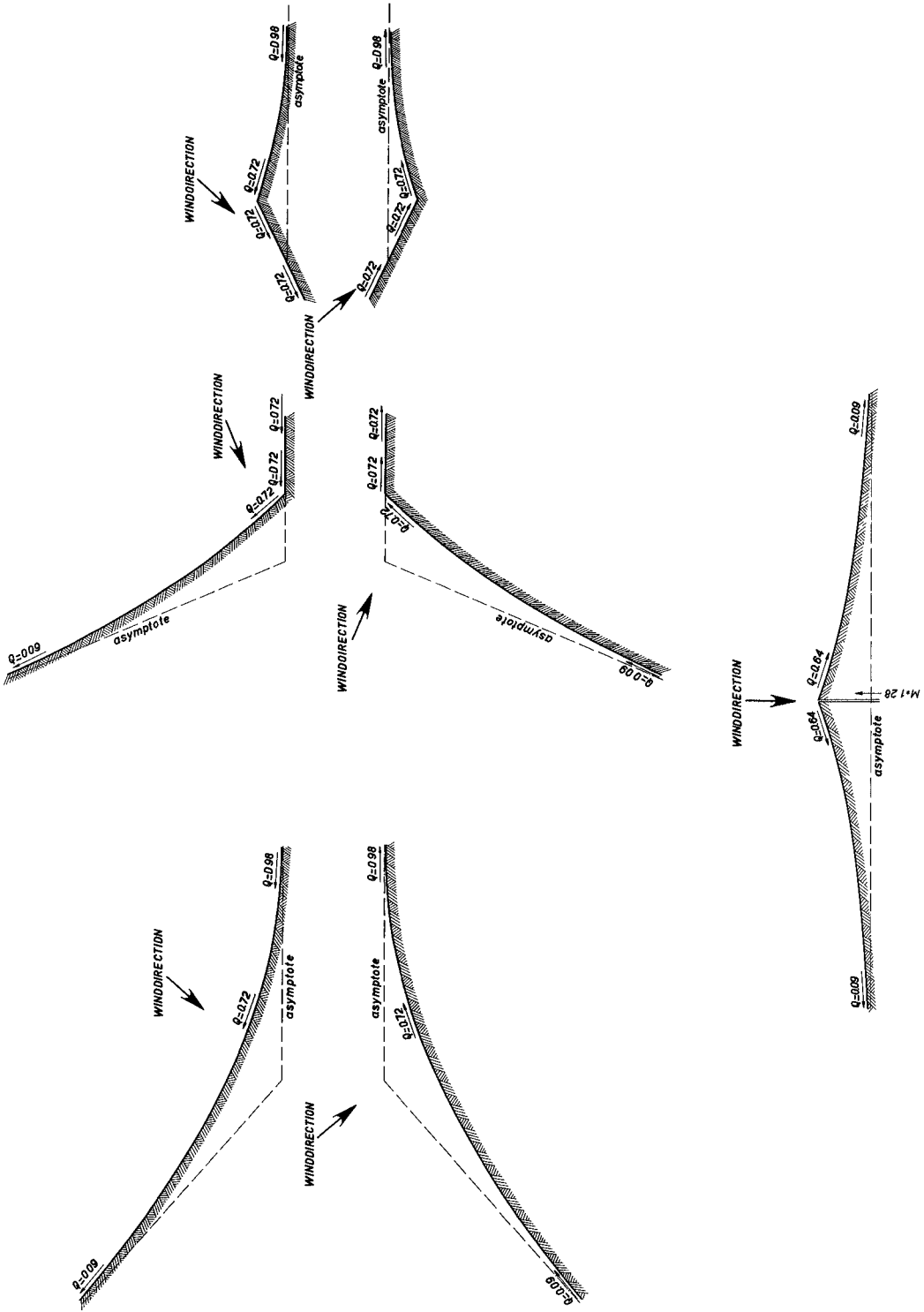

FIGURE 6

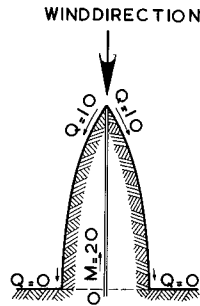
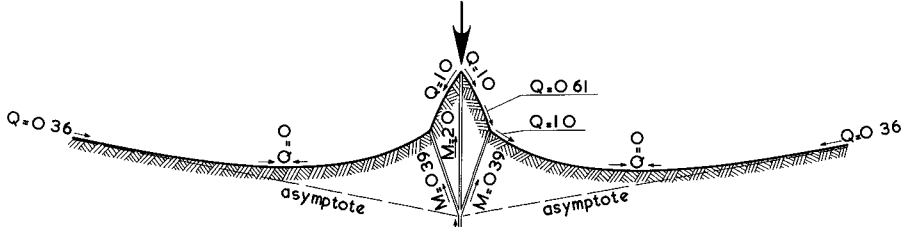
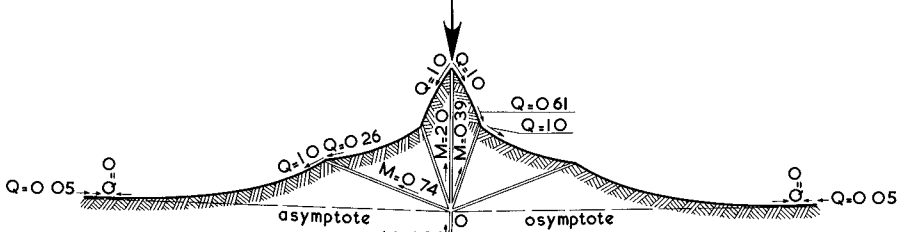

FIGURE 7



WIND DIRECTION



WIND DIRECTION

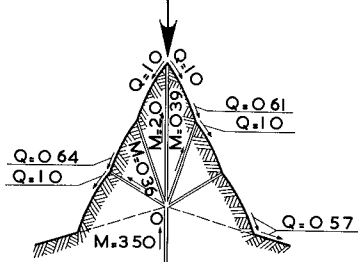

WIND DIRECTION

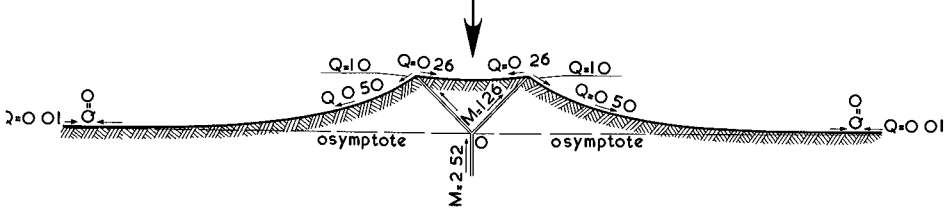

FIGURE 8

we have to do is to connect on the left hand side other curves as on the right hand side (figure 9). We can construct an infinite number of shorelines. By the way some of the original shores in the figures 8 and 9 have the shape of a bay or of a cape.

But there is still another way to construct non-symmetrical deltas. Till yet we have put β equal to zero. That means that the wind direction has been always perpendicular to the polar axis. When we take $\beta = -20^\circ$ we can construct the set of curves shown in figure 10. The curves on the right hand side of the line d have a cusp in the point where the littoral transport reaches its maximum value. At one point A is indicated how the shoreline would continue when the computer was not been stopped in the cusp. With this second part of the curve the symmetrical simple delta form figure 7 has been constructed. On the left hand side of line d the curves have an asymptote with decreasing values of Q according to the flatness of the curve.

When we take $\beta = +20^\circ$ we can construct the set of curves of figure 11. Here also exists a locus of cusps. When we mirror the set of figure 11 with respect to the wind direction we can combine this set with that of figure 10 and obtain figure 12. Here we have in principle 32 non-symmetrical deltas. Note that by each value of the quantity of material that the river brings to the sea there exist two different forms of shorelines. The deltas indicated by a letter A and by a letter B are a pair where the ratio between the quantity of material conveyed by the river and the quantity of material the sea is able to transport is about 0,55. The deltas indicated by a letter D and by a letter E are a pair where this ratio is about 1,25. Only when this ratio becomes equal to two (the delta indicated by the letter F) there exist mathematically only one solution. These 5 deltas are drawn in figure ¹³~~12~~ separately.

It will be clear that in this way we can also construct non-symmetrical deltas with more rivermouths combined with bay - or cape shaped original shorelines. But before continuing this stude it seems necessary to investigate whether the results we have obtained can be recognized in nature or not.

ACKNOWLEDGEMENTS

I have to point out that this article would not have been written without the leading of dr. ir. J.C. Schönfeld in the mathematical treat-

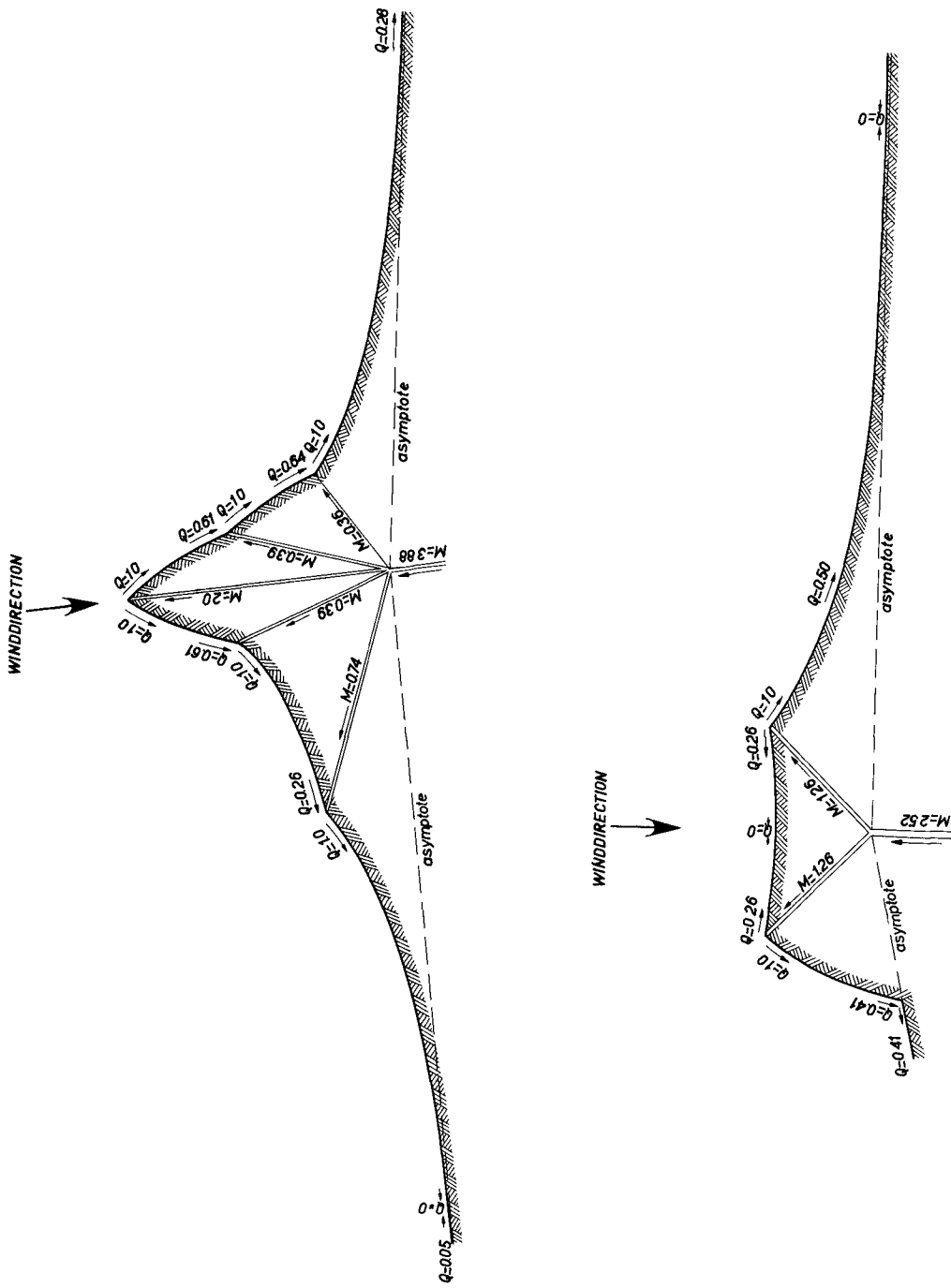

FIGURE 9

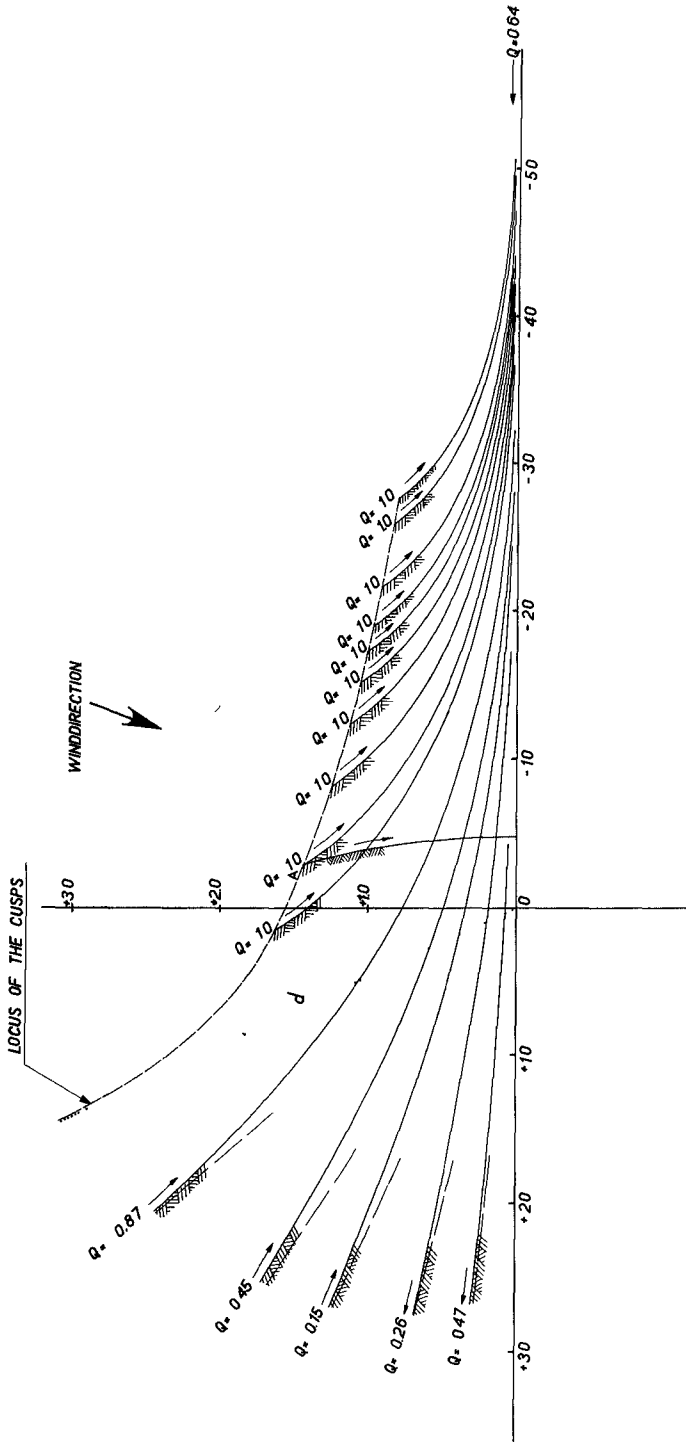

FIGURE 10

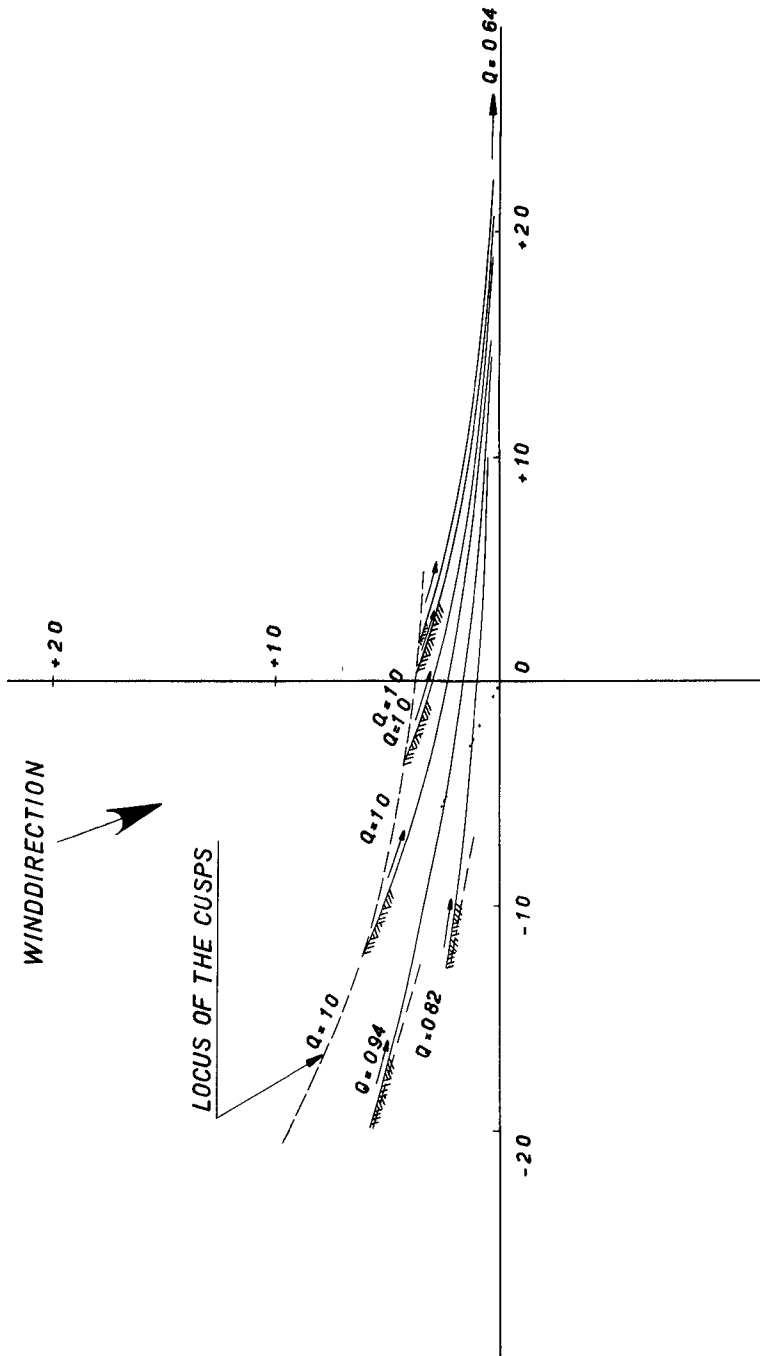

FIGURE 11

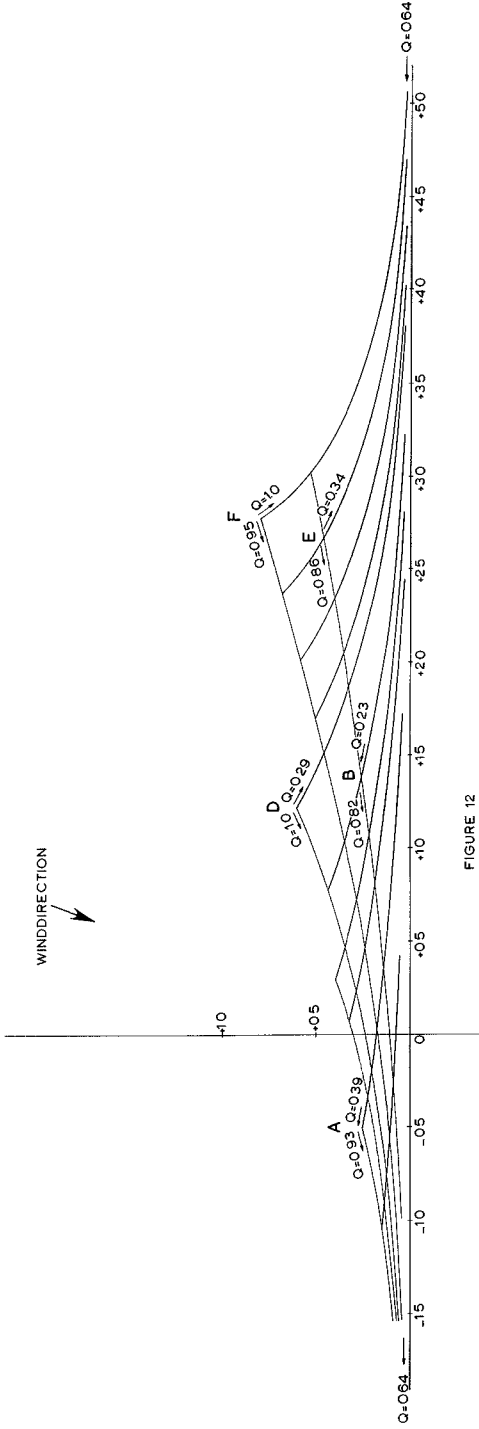

FIGURE 12

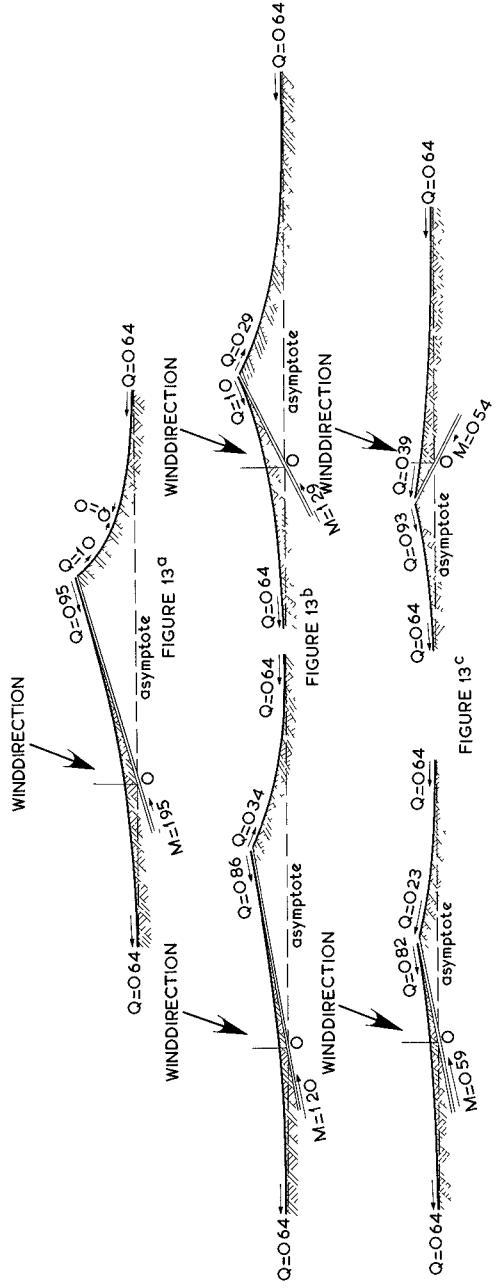

FIGURE 13 a

FIGURE 13 b

FIGURE 13 c

ment of the problem. Further I wish to express my thanks to mr. Bruyn, the assistant of dr. ir. Schönfeld, and to mr. Rundberg, my own assistant. Also I could not have dispensed with their dedicated assistance.
