

CHAPTER 112

RELATIONS BETWEEN THE RUN-UP AND OVERTOPPING OF WAVES

by

Shoshichiro Nagai*

Akira Takada**

ABSTRACT

The quantitative relationships among run-up, overtopping and reflection of waves are presented in this paper. In addition, the authors have proposed several empirical relationships to calculate the height of wave run-up and the quantity of wave overtopping in the region of standing waves.

INTRODUCTION

The run-up, overtopping and reflection of waves are mutually inter-related through the medium of wave energy, and these phenomena are remarkably affected by the slope of the sea-wall, the slope of the sea bottom, the wave steepness and the water depth at the toe of the sea-wall, showing complicated variation. Studies of this kind are few up to now, and several problems have been yet unsolved.

The slope of the sea-wall has much influence on the height and wave profile of run-up, the quantity of wave overtopping and the rate of reflection of waves. In this paper, the quantitative relationships among the phenomena of run-up, overtopping and reflection of waves are shown.

In addition, several empirical relationships have been proposed to calculate the height of wave run-up and the quantity of overtopping in the region of $h_1 \geq (h_b)_p$, in which h_1 is the water depth at the toe of a sea-wall and $(h_b)_p$ is the water depth of breaking of progressive waves, as shown in Fig. 1.

The definition diagram is shown in Fig. 2. In conducting the experiments, the impermeable and smooth slope was used.

* Professor of Hydraulic Engineering, Faculty of Engineering
Osaka City University, Osaka, Japan

** Associate Professor, Department of Civil Engineering
Chubu Institute of Technology, Nagoya, Japan

RATE OF WAVE REFLECTION, r

When the water depth at the toe of a sea-wall is larger than the depth of breaking of incident waves, the waves impinging against the slope of the sea-wall may be classified into the two kinds of surging waves and breaking waves, depending upon the slope of the sea-wall and the wave steepness. ^{(3),(4)}

Miche (1951) found that if the slope of the sea-wall was gentler than the critical slope, the waves in front of the sea-wall broke on the slope. The angle of the critical slope of the sea-wall, θ_c , which is related to the wave steepness in the deep water, $H\delta / L_0$, was given by the following Eq. (1) by Miche. ⁽⁴⁾

$$\frac{H\delta}{L_0} = \sqrt{2\theta_c / \pi} \cdot (\sin^2 \theta_c / \pi) \quad (1)$$

According to Miche, ⁽⁴⁾ the rate of wave reflection are given by

$$\frac{r}{\zeta} = 1 \quad \text{for} \quad \theta \geq \theta_c \quad (2)$$

$$\frac{r}{\zeta} = \sqrt{2\theta / \pi} \cdot (\sin^2 \theta / \pi) \cdot (H_0' / L_0)^{-1} \quad (3)$$

$$\text{for } \theta < \theta_c$$

in which ζ is a correcting coefficient of reflection (approximately equal to unit).

Eq. (2) and Eq. (3) have been already confirmed experimentally as shown in Fig. 3.

HEIGHT OF WAVE RUN-UP, R

It is hard to say that quantitative investigations on this problem have sufficiently been made so far. The authors have investigated the relationships between deep-water-wave steepness, $H\delta / L_0$, and the slope of the sea-wall giving the highest run-up as shown in Fig. 4.

$$(1) \text{ For Surging Waves } (H\delta / L_0 \leq \sqrt{2\theta} / \pi \cdot \sin^2 \theta / \pi)$$

The height of wave run-up, R , may be obtained by making use of both Miche's linear solution for surging waves and non-linear effect for finite amplitude standing waves as follows.

$$\frac{R}{H_0} = K_S (\sqrt{\pi / 2\theta} + \delta) \quad (4)$$

in which H_0 : wave height in deep water, θ : angle of inclination of a sea-wall to the horizontal plane, K_S : shoaling factor (= H_1 / H_0 , H_1 : wave height at the toe of a sea-wall), δ : the term representing the non-linear effect

$$\delta = (\eta_{(t)\max} - H_1) / H_1.$$

δ_S of Sainflou's equation⁽⁷⁾ for finite amplitude standing wave is given by

$$\delta_S = \frac{1}{2} k_1 H_1 \coth k_1 h_1 \quad (5)$$

in which h_1 : water depth at the toe of a sea-wall, $k_1 = 2\pi / L_1$, and L_1 : wave length at h_1 .

δ_{II} of the second-order solution⁽¹⁾ for finite amplitude standing wave is given by

$$\delta_{II} = (1/8) k_1 H_1 (3 \coth^3 k_1 h_1 + \tanh k_1 h_1) \quad (6)$$

δ_{III} of the third-order solution⁽⁸⁾ for finite amplitude standing wave is given by

$$\delta_{III} = \epsilon_A^2 \cdot \delta_{II} \quad (7)$$

in which ϵ_A (≤ 1) is expressed by

$$\epsilon_A = S^{1/3} \left\{ \left(\frac{1}{2} + \sqrt{\frac{1}{4} + \frac{S}{27}} \right)^{1/3} + \left(\frac{1}{2} - \sqrt{\frac{1}{4} + \frac{S}{27}} \right)^{1/3} \right\} \quad (8)$$

in which S is expressed by

$$S = \frac{2}{H_1^2 k_1^2 (b_{11} + b_{13} + b_{31} + b_{33})} \quad (9)$$

in which b_{11} , b_{13} , b_{31} and b_{33} are expressed as follows.

$$b_{11} = (1/32) (3\omega^{-2} + 6\omega^{-1} - 5 + 2\omega) \quad (10)$$

$$b_{13} = (3/128) (9\omega^{-2} + 27\omega^{-1} - 15 + \omega + 2\omega^2) \quad (11)$$

$$b_{31} = (1/128) (-3\omega^{-2} - 18\omega^{-1} + 5) \quad (12)$$

$$b_{33} = (3/128) (9\omega^{-3} - 3\omega^{-2} + 3\omega^{-1} - 1) \quad (13)$$

$$\text{in which } \omega = (\tanh k_1 h_1)^2 \quad (14)$$

δ_V of the fourth-order solution⁹⁾ for finite amplitude standing wave is given by

$$\delta_V = \delta_{III} + (1/6) (k, H, \epsilon_A^4) (b_{02} + b_{22} + b_{42} + b_{04} + b_{24} + b_{44}) \quad (15)$$

in which b_{02} , b_{22} , b_{42} , b_{04} , b_{24} and b_{44} are shown as follows.

$$b_{02} = (1/512\sqrt{\omega}) (-27\omega^{-2} + 288\omega^{-1} + 168 - 210\omega - 45\omega^2 + 18\omega^3) \quad (16)$$

$$b_{22} = (1/512\sqrt{\omega}) (-81\omega^4 - 54\omega^3 + 423\omega^2 - 583\omega^{-1} + 108 - 195\omega - 18\omega^2) \quad (17)$$

$$b_{24} = \{ 1/512 (3+\omega)\sqrt{\omega} \} (324\omega^3 + 2484\omega^{-2} - 1152\omega^{-1} - 2072 + 1092\omega + 420\omega^2 - 72\omega^3) \quad (18)$$

$$b_{04} = (1/512\sqrt{\omega}) (54\omega^3 + 243\omega^2 + 198\omega^{-1} + 6 - 198\omega + 63\omega^2 + 18\omega^3) \quad (19)$$

$$b_{42} = \{ 1/512 (3+4\omega)\sqrt{\omega} \} (-81\omega^3 - 1053\omega^2 + 63\omega^{-1} - 283 + 282\omega) \quad (20)$$

$$b_{44} = \{ 1/512 (5+\omega)\sqrt{\omega} \} (405\omega^4 + 81\omega^3 + 522\omega^2 - 262\omega^{-1} + 1 + 21\omega) \quad (21)$$

The calculated values of the term representing the non-linear effect, δ were compared with the experimental values, as shown in Fig. 5.

In Fig. 5, δ_{III} or δ_{IV} give generally quite appropriate values in the region of standing waves, but they give slightly smaller values in the region of breaking waves on $\tan\alpha = 1/30$ or $1/10$. The reason was considered that the small amplitude wave theory was used for the calculation of K_S and there were some sprays of waves on the slopes.

On the other hand, δ_{II} gives larger values in general but gives suitable values in the region of breaking waves on the slope of the sea-bottom bottom $\tan\alpha = 1/30$ or $1/10$.

Therefore, it was decided to use δ_{II} from a point of view of the practical use.

(2) For Breaking Waves ($H_0 / L_0 > \sqrt{2} \theta / \pi \cdot \sin^2 \theta / \pi$)

Hunt (1959) proposed a formula to calculate the height of wave run-up in the breaking waves region.⁽³⁾

However, in Hunt's equation, the condition near the boundary between the surging waves region and the breaking waves region are not considered as shown in Fig. 6.

Therefore the Eq. (22) was proposed for the cases when the slope of a sea-wall $\tan\theta \geq 1/8$,

$$\frac{R}{H_0} = K_S \left(\sqrt{\pi / 2 \theta} \frac{1}{C} + \delta \right) \left(\tan\theta / \tan\theta_C \right)^{2/3} \quad (22)$$

in which, θ_C is the angle of the gentlest slope that produces surging waves which C can be calculated in Eq. (1).

Fig. 7 shows the comparisons of the experimental values with the calculated values of the height of the wave run-up, R/H_0 , indicating a fairly good agreement of the experimental values with the calculated values. The values of δ_{II} shows a considerable applicability as shown in Fig. 8.

QUANTITY OF WAVE OVERTOPPING, Q

The phenomena of wave overtopping occur when the crown height of the sea-wall is lower than the height of the wave run-up.

As to the maximum quantity of overtopping, the relationships between the slope angle of the sea-wall and the deep-water-wave steepness were studied by experiments. Fig. 9 shows the results. According to Fig. 9, the maximum overtopping of waves occurs at the critical region between surging waves and breaking waves.

There are two methods to relate the height of wave run-up to the quantity of overtopping. One is the method which uses the profile of wave run-up,⁽¹⁰⁾ and the other uses the surface elevation of wave run-up on the front of the sea-wall.^{(11) (12)}

This study is concerned with the former, but whichever method is used, it is thought to be of practical importance to find out a response function against the incident waves.

(1) For the Vertical Wall

It was assumed that the quantity of overtopping for a constant wave period, Q , is proportional to the water volume of the run-up wave above the crown height of the sea-wall, V . From Fig. 10,

$$Q = a B V \quad (23)$$

in which a : the coefficient for quantity of overtopping, B : the width of overtopping.

If the wave profile obtained from the second-order approximation is used of finite amplitude standing wave theory without overtopping, the water quantity of overtopping can be calculated.

$$\begin{aligned} Q &= a_{II} B \int_0^{x_c} \{ \eta_{II}(x) - H_c \} dx \\ &= a_{II} B [(H_1 / k_1) \sin k_1 x_c \\ &\quad + (H_1^2 / 16) (3 \coth^3 k_1 h_1 + \tanh k_1 h_1) \sin 2 k_1 x_c \\ &\quad - H_c x_c] \end{aligned} \quad (24)$$

in which H_c : the crown height of a sea-wall from the still water level, $\eta_{II}(x)$: the profile of wave run-up of the second-order solution of finite amplitude standing wave theory, and x_c ($< L_1 / 4$) can be obtained by $\eta_{II}(x) = H_c$.

$$\cos k_1 x_c = (1 / 4 d) (\sqrt{ H_1^2 + 8 d (d + H_c) } - H_1) \quad (25)$$

in which

$$d = (1 / 8) k_1 H_1^2 (3 \coth^3 k_1 h_1 + \tanh k_1 h_1) \quad (26)$$

when $h_1 \geq (h_b)_s$, in which $(h_b)_s$ defines the water depth of breaking of standing waves, a_{II} is given by the following equation, which was obtained by the experiments

$$a_{II} = 9.3 (H_0 / L_0) \left(\frac{R_{II} - H_c}{H_1} \right)^{1/2} \quad (27)$$

in which R_{II} shows the height of wave run-up of the second-order approximation of finite amplitude standing wave theory.

The quantities of overtopping obtained by the experiments were compared with the calculated ones, as shown in Fig. 11.

Fig. 11 shows that Eq.(24) may be stated to be in a fairly good agreement with the experimental values. The mean value of Q_{exp} / Q_{cal} , (Q_{exp} / Q_{cal}), and the standard deviation, σ , are given by

$$\left(\frac{Q_{\text{exp}}}{Q_{\text{cal}}} \right) = 0.98$$

and

$$\sigma = \sqrt{\frac{1}{N} \sum_{i=1}^N \left\{ \frac{Q_{\text{exp}}}{Q_{\text{cal}}} - \left(\frac{Q_{\text{exp}}}{Q_{\text{cal}}} \right) \right\}^2} = 0.28 \quad (28)$$

When $h_1 = (h_b)_p \sim (h_b)_s$ and $\tan \alpha = 1/10$, in which $(h_b)_p$ denotes the water depth of breaking of progressive wave and $\tan \alpha$ is the slope, a_{II} is given by

$$a_{\text{II}} = 5.5 \left[h_1 / (h_b)_s \right]^{2/3} (H_0^2 / L_0) \left(\frac{R_{\text{II}} - H_C}{H_1} \right)^{1/2} \quad (29)$$

Values of $\left(\frac{Q_{\text{exp}}}{Q_{\text{cal}}} \right)$ and σ for Eq. (29) are given by

$$\left(\frac{Q_{\text{exp}}}{Q_{\text{cal}}} \right) = 1.10$$

and

$$\sigma = 0.40 \quad (30)$$

Further investigations are needed to get higher accuracy.

(2) For the Sloping Wall

If the wave profile running up on the slope of the sea-wall in the case of non-overtopping of waves can be approximated by a trapezoid, as shown in Fig. 12. The quantity of overtopping is obtained by the following equation.

$$Q = a_{\theta} B V \left[\frac{(1 + \cot^2 \theta) (R_{\text{II}} - H_C)^2}{2 (\cot \gamma - \cot \theta)} + 0.15 H_1 (R_{\text{II}} - H_C) \right] \quad (31)$$

in which $(a_{\theta})_{\text{II}}$ denotes the coefficient for quantity of overtopping, γ is an angle at the edge of the profile of run-up wave. $\cot \gamma$ is given by the following equations, obtained by the experiments,

when $\cot \theta \geq 1$,

$$\cot \gamma = 67 (H_1 / L_1) (\cot \theta)^{1.6} \quad (32)$$

when $\cot \theta = 0 \sim 1$,

$$\cot \gamma = \left\{ n + \frac{n(n-1)}{2} \cot^2 \theta \right\}^{1/2} \cot \theta \quad (33)$$

in which

$$n = - 3.224 \log_{10} \left\{ \frac{1}{1 + (67 H_1 / L_1)^2} \right\} \quad (34)$$

Fig. 13 shows that the comparison between the experimental and calculated values may be stated to be in a fairly good agreement.

When $h_1 \geq (h_b)_s$, $(a_\theta)_II$ is given by the following equation obtained by the experiments.

$$(a_\theta)_II = 7.6 (\cot \theta)^{0.73} (H_0' / L_0)^{0.83} \quad (35)$$

Fig. 14 shows that the comparison between the experimental and calculated values may be stated to be in a fairly good agreement.

Values of (Q_{exp} / Q_{cal}) and σ calculated by Eq.(35) are

$$(Q_{exp} / Q_{cal}) = 1.00 \quad (36)$$

and

$$\sigma = 0.35$$

When $h_1 = (h_b)_p \sim (h_b)_s$ and $\tan \alpha = 1/10$, $(a_\theta)_II$ is given by the following equation.

$$\begin{aligned} \log_{10} (a_\theta)_II &= \log_{10} 6.6 + 1.8 \log_{10} \{ h_1 / (h_b)_s \} \\ &+ 2 \left\{ \frac{(h_b)_s - h_1}{(h_b)_s - (h_b)_p} \right\} \log_{10} \left(\frac{R_{II} - H_c}{H_1} \right) \\ &+ 0.73 \log_{10} \cot \theta + 0.83 \log_{10} H_0' / L_0 \end{aligned} \quad (37)$$

Values of (Q_{exp} / Q_{cal}) and σ calculated by Eq.(37) are

$$(Q_{exp} / Q_{cal}) = 1.00 \quad (38)$$

and

$$\sigma = 0.51$$

Further experiments are needed to get higher accuracy.

CONCLUSIONS

In the previous studies, the run-up, overtopping and reflection of waves were studied as an independent phenomenon, and their interrelationships have never been discussed adequately.

In this paper, the calculation formulae were proposed for the height of wave run-up and the quantity of overtopping, and proved to give fairly good values to the experimental values.

Furthermore, relationships between the height of wave run-up, quantity of overtopping and the rate of reflection of waves were investigated by experiments. Their correlations were presented in details, and summarized in Fig. 15.

It is clear in Fig. 15 that the slope which produces the highest run-up of waves is nearly in agreement with not only the slope which produces the maximum overtopping, but also the gentlest slope that produces the total reflection. In other words, the highest run-up of waves and the maximum overtopping of waves arise generally in the critical region between surging waves and breaking waves. The equation for the critical condition is generally shown in Eq. (1) for the region of standing waves.

REFERENCES

- (1) Miche, M. : Mouvements ondulatoires de la mer en profondeur constance ou décroissante. (I ~ IV), Annales des Ponts et Chaussées, Vol.121, pp. 25 ~ 78, 131 ~ 164, 270 ~ 292, 369 ~ 406, 1944.
- (2) Kishi, T. : Researches on sea-walls (2) - On the shallow clapotis of finite amplitude -, The Public Work Research Institute, Ministry of Construction, Vol. 90, pp. 27 ~ 54, March, 1955, (in Japanese).
- (3) Hunt, I. A. : Design of sea-walls and breakwaters, Proc., ASCE, Vol. 85, No. WW3, Sep., 1959.
- (4) Miche, M. : Le pouvoir réfléchissant des ouvrages maritimes, Annales des Ponts et Chaussées, May-June, 1951.
- (5) Murota, A : Experimental researches on reflection of roughness slopes, Proc., 14th Conf. on Coastal Engineering in Japan, pp. 45 ~ 48, Oct., 1967, (in Japanese).
- (6) Le Méhauté, B., Koh, R. C. Y. and Hwang, Li-San : A synthesis on wave run-up, Proc., ASCE, Vol. 94, No. WW1, Feb., 1968.
- (7) Sainflou, G. : Essai sur les disques maritimes verticales, Annales des Ponts et Chaussées, Vol. 98, No. 4, 1928.
- (8) Tadjbakhsh, I. and Keller : Standing surface waves of finite amplitude, Journal of Fluid Mechanics, Vol. 8, pp. 442 ~ 451, 1960.

- (9) Goda, Y. : The Fourth order approximation to the pressure of standing waves, Coastal Engineering in Japan, Vol. 10, pp. 1 ~ 11, Vol. 11, 1967, (Errata, Coastal Engineering in Japan, Vol. 11, pp. 197, 1968)
- (10) Takada, A. : On relations among wave run-up, overtopping and reflection, Proc., The Japan Society of Civil Engineers, No. 182, pp. 18 ~ 30, Oct., 1970.
- (11) Shiigai, H. and Kono, T : Analytical approach on wave overtopping on levees, Proc., The 12th Coastal Engineering Conference, Vol. 1, pp. 563 ~ 573, Sep., 1970.
- (12) Takada, A. : Wave overtopping quantity correlated to the surface elevation of finite amplitude clapotis, Proc., The Japan Society of Civil Engineers, No. 201, pp 61 ~ 76, May, 1972, (in Japanese).
- (13) Hamada, T. : Secondary interaction of surface waves, Report of Port and Harbour Research Institute, Ministry of Transport, Japan, No. 10, 1965.

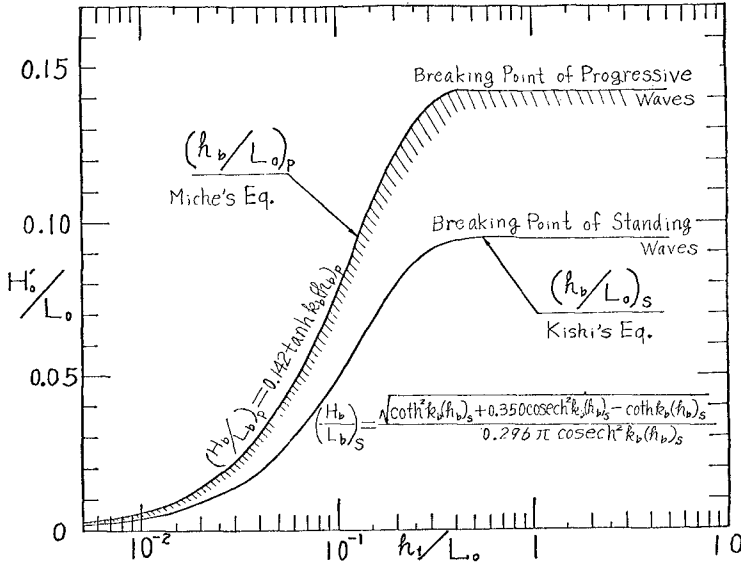

Fig. 1. Breaking point of progressive waves and standing waves (Applicable region in this paper)

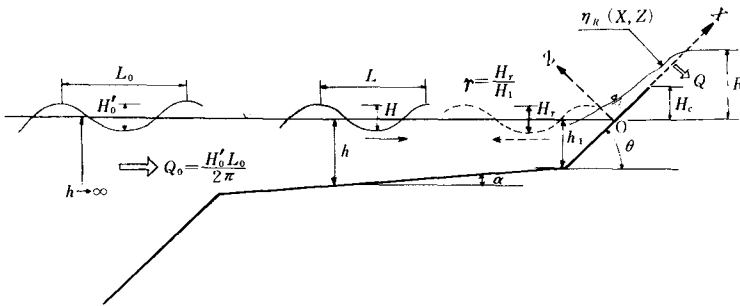

Fig. 2. The definition diagram in this paper

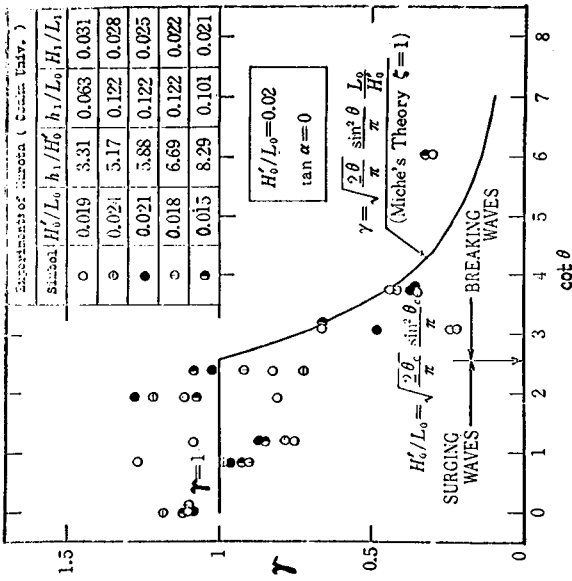

Fig. 3. Comparison between theoretical and experimental values of the rate of reflection

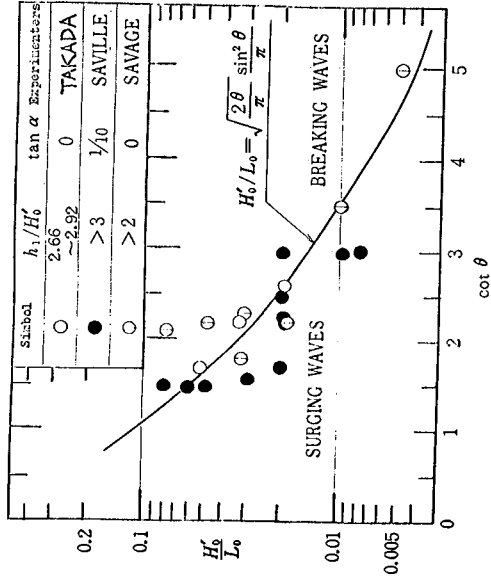

Fig. 4. Condition generating the maximum height of wave run-up, R_{max}
 (Relations between $\cot \theta$ and H_0 / L_0)

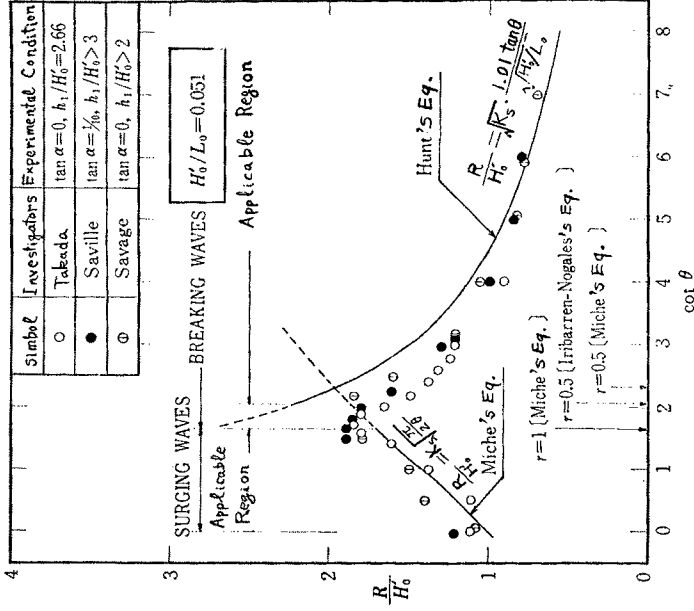

Fig. 6. Miche's equation and Hunt's equation of wave run-up R/H_0 (Comparison between calculated and experimental values)

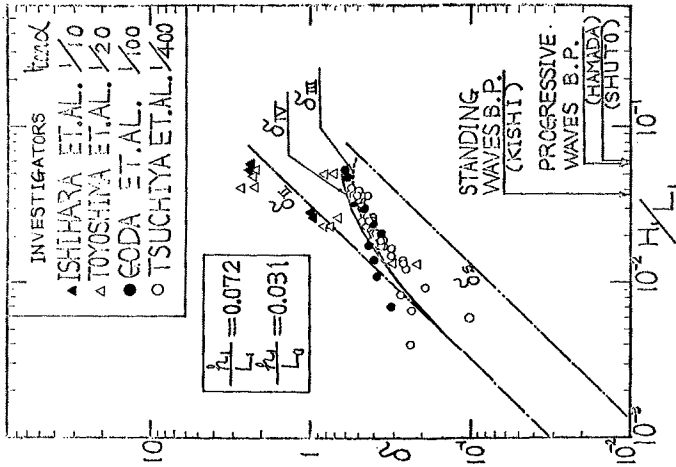

Fig. 5. Comparison between theoretical and experimental values of the term representing the non-linear effect, δ

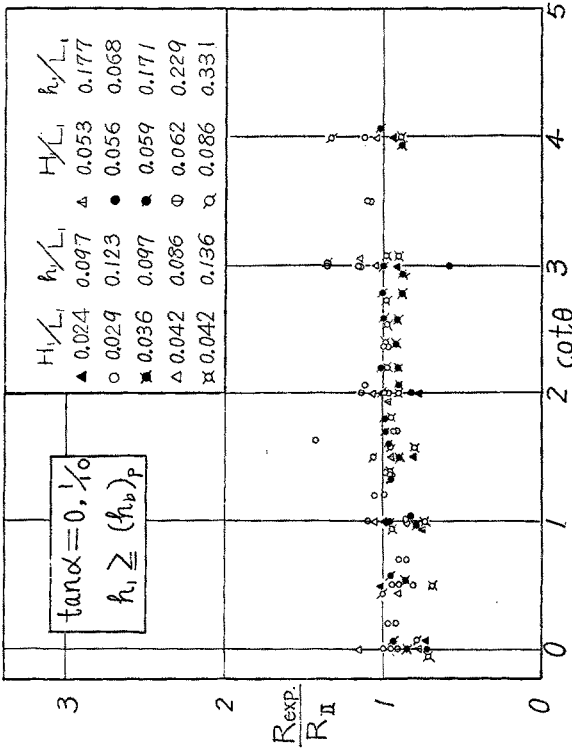

Fig. 8. Comparison between calculated values using δ_r and experimental values of the height of wave run-up, R

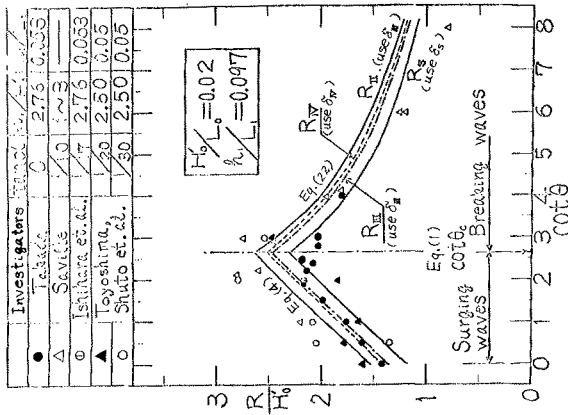

Fig. 7. Comparison between calculated and experimental values of the height of run-up, R / H₀

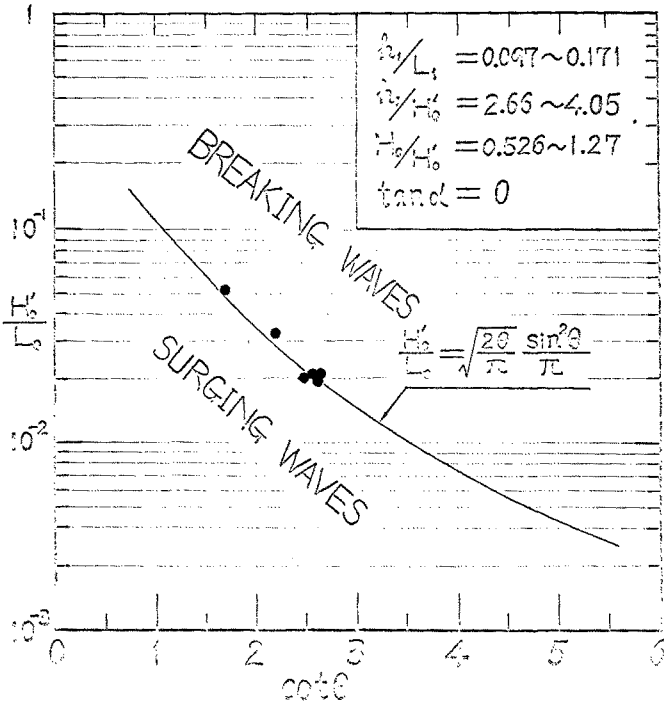

Fig. 9. Condition generating maximum quantity of wave overtopping, Q_{max}
 (Relations between $\cot \theta$ and H_b / L_0)

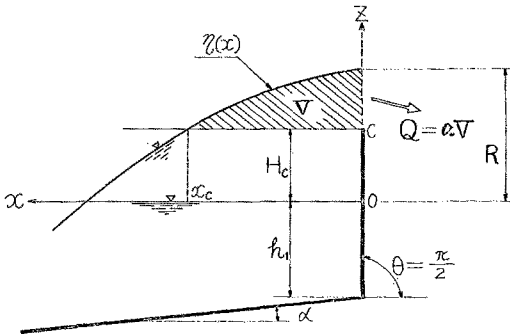

Fig. 10. Relations between a profile of run-up wave and the quantity of wave overtopping for vertical wall

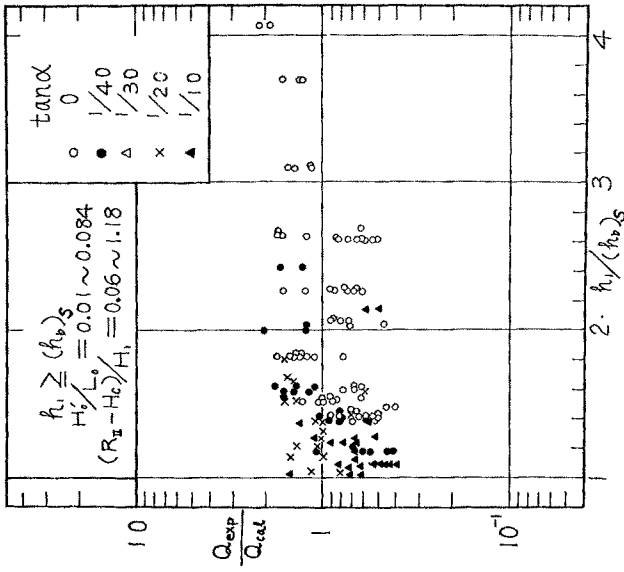

Fig. 11. Comparison between calculated and experimental values of quantity of wave overtopping for $h_1 \geq (h_b)^{0.5}$

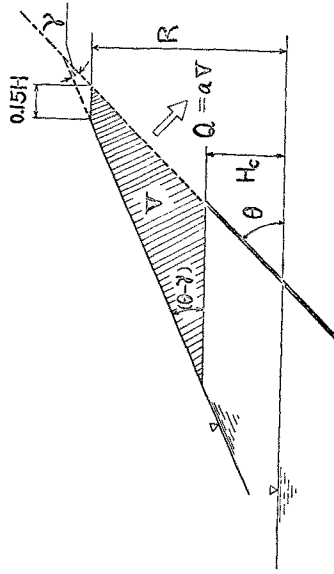

Fig. 12. Relations between wave profile of run-up and quantity of wave overtopping for sloping wall

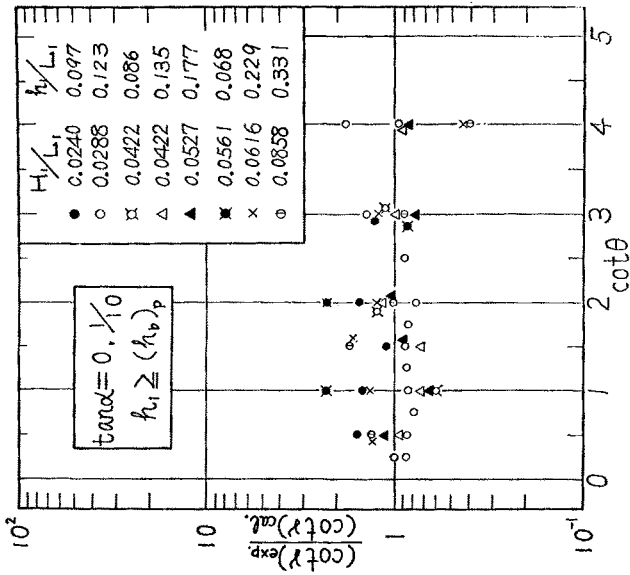

Fig. 13. Comparison between calculated and experimental values of an angle at the edge of the profile of wave run-up, $\cot \gamma$

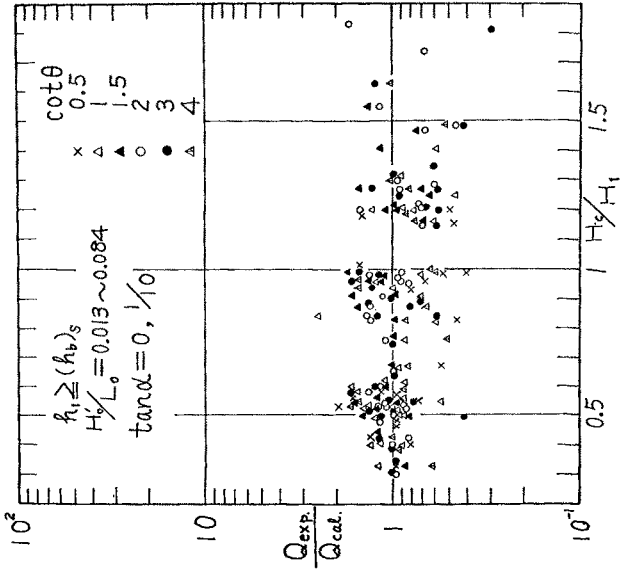

Fig. 14. Comparison between calculated and experimental values of quantity of wave overtopping for $h_1 \geq (h_b)_s$

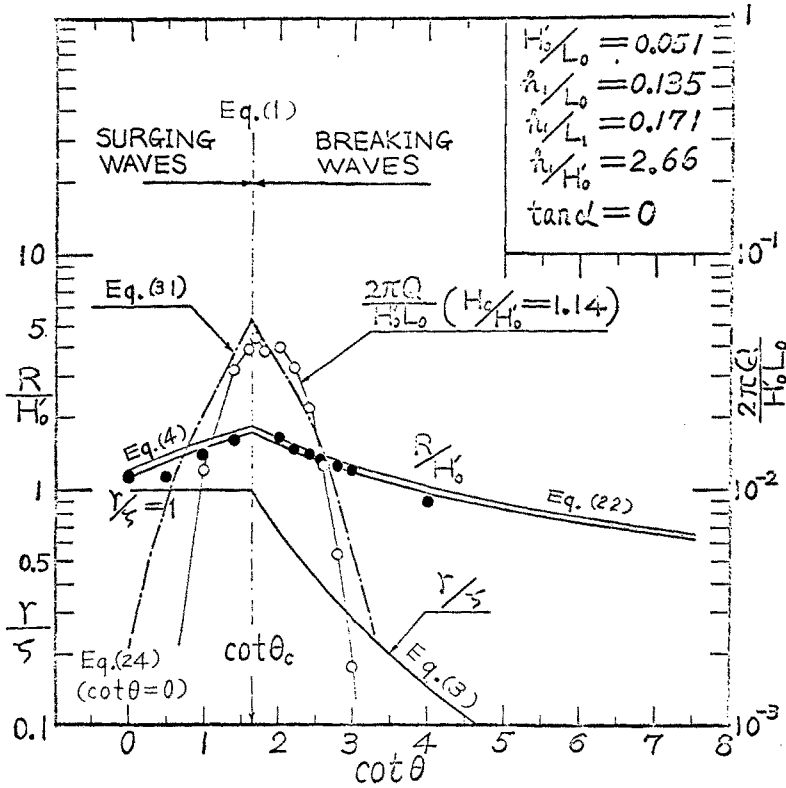

Fig. 15. Correlation characteristics among run-up, overtopping and reflection of waves