

**PIER PROTECTION SYSTEM FOR
THE DUWAMISH SHIP CHANNEL IN SEATTLE**

Y. Eisenberg¹; M. ASCE

ABSTRACT

In 1978 an out-of-control ship hit and severely damaged a bascule bridge across the Duwamish West Waterway in Seattle seriously affecting both ship and highway traffic. The high level West Seattle Bridge was subsequently constructed to handle all through-highway traffic. A swing bridge was also designed to handle local traffic over the ship channel. The function of the pier protection system described in this paper is to protect the pivot piers and swing spans of this new bridge from damage by absorbing the part of the transverse energy component imparted by a colliding ship, which is not absorbed by deformation of the ship's hull.

1. DESIGN

The Duwamish ship channel in the Port of Seattle, Washington will be widened from 150 to 250 feet (46 to 76 meters) and deepened to 43 feet (13 meters) below mean low low water (MLLW), thereby accommodating ships with displacement of up to 100,000 kips (45,000 tons) and a length of 650 feet (200 meters). The pier protection system to be placed along the edge of the channel shall provide protection for the pivot piers and the open swing span superstructures from ship impact.

1.1 DESIGN ASSUMPTIONS

1.1.1 Design Vessel

The maximum size of vessel which is expected to use the Duwamish waterway has a displacement of 100,000 kips (45,000 tons) and a length of 650 feet (200 meters).

1.1.2 Design Collision

The pier protection was designed to protect the bridge elements from the impact of the assumed design vessel moving at three knots or 5 ft. (1.5 meters)/sec. at an angle of between 0 and 18 degrees to the centerline of the channel. A transverse impact of the stern of the ship was also considered.

Impacts in the longitudinal (head-on) direction were assumed at each end of the pier protection system only.

¹ Parsons Brinckerhoff Quade & Douglas, Inc.
San Francisco, California, U.S.A.

It was further assumed that transverse impacts may occur anywhere along the pier protection system.

1.1.3 Design Energy

1.1.3.1 Longitudinal

The kinetic energy of the ship in the longitudinal direction was taken as:

$KE_L = \frac{1}{2} MV^2$ with M = Mass of the ship
and V = Velocity of the ship

$KE_L = \frac{1}{2} \times \frac{100,000}{32.2} \times 5^2 = 38,000 \text{ ft.-kips,}$
say 40,000 ft.-kips (5,500 meter-tons)

1.1.3.2 Transverse

The transverse component of the 5 ft. (1.5 m)/sec. velocity at an angle of 18 degrees is 1.55 ft. (0.47 m)/sec.

In addition, in the transverse direction, a factor of about 1.0 must be added to account for the hydrodynamic mass of the water behind the vessel.

Therefore, total $KE = \frac{1}{2} \frac{100,000}{32.2} \times 1.55^2 (1+1) =$
7,500 ft.-kips (1,040 meter-tons).

A vessel trying to correct course may impact the pier protection with its stern. As there are no reliable data available for this type of impact, the use of a somewhat higher transverse design energy seemed prudent. Therefore, a value of 10,000 ft.-kips (1,400 meter-tons) was finally used.

1.1.4 Transverse Clearance

The height of the pier protection system was selected to restrain the ship deck overhangs of the design vessel from damaging the bridge. For purpose of the design of the pier protection, low water was taken as elev. -12 ft. (-3.66 m) and high water was taken as elev. 0.0. All elevations were based on the City of Seattle datum.

1.2 LOAD RESISTANCE FOR DESIGN IMPACTS

A collision of a fully-loaded design vessel at the design speed and angle has a very low probability of occurring. The normal design safety factors were, therefore, not applied. The total resistance of the pier protection system was utilized, and

the timber protection was considered expendable for anything other than minor impacts.

1.2.1 Longitudinal Design

At each end of the pier protection system, a concrete topped sheet pile cell will protect the bridge from head-on impact. If the full design energy will have to be dissipated, it was assumed that substantial damage to both the pier protection system and the vessel will occur.

1.2.2 Transverse Design

The pier protection system for transverse impacts consists of timber facing, reinforced concrete distribution beam and rubber fenders. This system will be supported by dolphins on piles.

To absorb the full transverse design energy, the plastic deformation of the pier protection system and of the vessel will take place, resulting in damage requiring repair work to both the pier protection and the vessel.

1.3 OTHER COLLISIONS

1.3.1 Usual Collisions

The usual type of collision to be expected is a glancing blow by a vessel. This will require an energy dissipation of a small percentage of the full design energy. Another probable occurrence is that of a ship which may drift sideways and use the pier protection system as a guideway.

A timber facing consisting of rubbing planks (placed from elev. -12 ft. (-3.66 m) to +2 ft. (+0.61 m) and timber piles shall run the full length and extend at least 30 feet beyond the center of each end cell. At this point, the timber protection shall be turned around a pile cluster toward the bank of the waterway.

This timber protection will limit damage to ships at low energy impacts. Damage which may occur to the timber elements will be relatively easy to repair.

1.3.2 Collision Exceeding Design

An effort has been made to provide a reasonable level of protection for the bridge. It must be recognized, however, that it is possible that the waterway may be used by larger vessels or vessels of unusual configuration. It was not deemed to be economical to try to prevent damage to the bridge for all possible impact conditions. Therefore, some risk factors remain.

1.4 DESIGN COMPONENTS

The pier protection system (see Figures 1, 2 and 3 - Plan, Elevation and Section) consists of the following components:

- o Timber piles (with timber facing) driven to 15 to 20 feet (5 to 6 meters) below channel bottom and end cluster dolphins, one at each corner of the pier protection system. (See Figure 2)
- o Small timber and structural steel wale system for transmitting loads from the timber piles and facing to the reinforced concrete distribution beams. (See Figure 3)
- o Reinforced concrete distribution beams. (See Figure 3)
- o Rubber fendering units transmitting horizontal loads from the distribution beams to the reinforced concrete dolphins. (See Figure 4)
- o Reinforced concrete dolphins vertically supporting the distribution beams and resting on batter piles. (See Figure 3)
- o Supporting struts carrying horizontal loads from the distribution beams to the reaction blocks. (See Figure 3)
- o Reinforced concrete reaction blocks. (See Figure 3)
- o Sheet pile cells, one at each corner of the pier protection system. (See Figure 1)

The various components of the pier protection system are described below:

Timber piles with timber facing and end cluster dolphins

The timber piles will be driven to a depth of 15 to 20 feet (5 to 6 meters) below the channel bottom. They are essentially designed to withstand only minor scraping by passing ships and to protect small craft. A blow of any consequence will surely damage or destroy them, but they can be easily replaced.

Timber and structural steel wale system

The wale system consists of 12 inch x 12 inch (0.30 m x 0.30 m) timber wales and structural steel WT members and its function is to tie the timber pile system to the distribution beams and thereby facilitate the transmission of loads from the piles to the beams.

Reinforced concrete distribution beams

The distribution beams are continuous reinforced concrete beams with spans varying from 115 feet to 132 feet (35 to 40 meters).

They are supported vertically on reinforced concrete dolphins and on intermediate 18-inch (450 mm) diameter pipe piles and are restrained laterally by fendering units.

The pipe piles are provided to assist in resisting an instantaneous vertical component from a ship impact at midspan of the distribution beam. Both dolphins and fenders are discussed further below. The distribution beams, whose main function is to transmit lateral ship loads, are approximately 4 feet (1.25 meters) high and 12 feet (3.65 meters) wide. They are designed to withstand at yield an equivalent horizontal colliding ship load in excess of 2,000 kips (900 tons). Stainless steel plates are embedded in the concrete dolphin surfaces interfacing with the distribution beams to facilitate lateral sliding. The distribution beams are restrained from moving laterally by energy-absorbing rubber fenders that have lateral displacement capacity of almost 5 feet (1.50 meters).

Fendering Units

The function of the fenders is to absorb the colliding ship's energy as they compress and transmit the lateral loads from the distribution beams to the supporting dolphins. The buckling column type fenders are composed of trapezoidally-shaped rubber manufactured by several producers. The corner fenders (1,500L x 2,500H) are over 8 feet (2.5 meters) thick. The intermediate fenders (1,500L x 2,000H) are over 6 feet (2.0 meters) thick. The corner fenders are sized to absorb up to 3,000 foot-kips (415 meter-tons) of energy with a reaction of 2,000 kips (900 tons) at each dolphin. The intermediate fenders are sized to absorb up to 2,000 foot-kips (280 meter-tons) of energy with a reaction of 1,900 kips (800 tons) at each dolphin.

Reinforced Concrete Dolphins

The reinforced concrete dolphins are supported vertically by two 36-inch (915 mm) diameter batter piles. The piles are battered in the longitudinal direction, i.e., in the direction of ship traffic, and provide some resistance to longitudinal impacting ship forces. The dolphins' main function, however, is to transmit the lateral impacting ship forces through the timber piles, wale system, distribution beams and fender units and on to the supporting struts.

Supporting Struts

The supporting struts, which are about 60 to 100 feet (18 to 30 meters) long, are composed of 48-inch (1,220 mm) diameter steel pipes with a compressive ultimate capacity of 2,500-3,000 kips (1,100 to 1,400 tons). The function of the supporting struts is to carry the lateral loads from the reinforced concrete dolphins to the reaction blocks.

Reinforced Concrete Reaction Blocks

The reaction blocks and supporting struts will be placed in sheeted or bentonite slurry trenches. The reaction blocks, which are 20 feet (6 meters) high and 25 feet (7.6 meters) wide are designed to mobilize sufficient ultimate passive soil pressure, at 550 lbs/ft³ (8800 kg/m³) equivalent fluid pressure, behind them to withstand a minimum lateral load of 3000 kips (1400 tons) on any strut. In fact, the supporting struts are designed to buckle or yield at below 3,000 kips (1400 tons) load to forestall backward movement and upward heave of the soil behind the reaction blocks.

Sheet Pile Cells

The sheet pile cells are composed of 45-foot (13.7 meters) diameter interlocking sheet piles driven to elev. -75 feet (-23 meters) or about 20 feet (6 meters) below the channel bottom. They are filled with compacted or densified sand and gravel and are capped with 5 feet (1.5 meters) of reinforced concrete to elev. 0. Their function is to act as crash barriers at the four corners of the pier protection system. They are able to withstand a lateral or longitudinal force of about 2,600 kips (1200 tons) by a ship in the channel with 6-inch (0.15 meters) to one-foot (0.3 meters) displacement, and a force of up to about 3200 kips (1,450 tons) while being permanently displaced by no more than 4 to 5 feet (1.2 to 1.5 meters) in the process. While being thus damaged, the sheet pile cells will, in the process, deflect serious damage from the swing bridge and other components of the pier protection system.

Total Pier Protection System

The energy absorption capacity of the total pier protection system, just prior to its collapse is about 10,000 to 12,000 foot-kips (1400 to 1700 meter-tons).

1.5 DESIGN PROCESS

Since it was assumed that a design level impact will be such an infrequent occurrence, structural yielding was permitted as an energy dissipating device, as mentioned before. The pier protection system elements will yield as follows: the timber fendering will crush; the distribution beam will form plastic hinges; some rubber marine fender will be crushed; some struts will develop plastic hinges; some intermediate supports will develop plastic hinges; the colliding ship's hull will be deformed; and some sheet pile cells will deform plastically.

The distribution beams were modeled to reflect the beam spans, size and support conditions including the nonlinear behavior of large rubber marine fenders. The model was loaded either in spans or at supports with a uniform load of a magnitude

corresponding to a yield stress on the ship's hull. This is a maximum unit force that the ship can impart to the distribution beam. The magnitude of the force can increase only by increasing the area of ship yielding, i.e., the contact length. The ship can contact the distribution beam at one area for a given collision; therefore, only single spans or single supports are loaded. The load length is increased until either the energy requirements are met or the beam undergoes structural yielding. When yielding occurs, a plastic hinge is applied to the model and the load is increased. To install a plastic hinge, a member end is released for rotation and equal and opposite hinge capacity movements are applied to the member ends framing into the joint. The load is then increased until energy requirements are met while checking that secondary hinges do not form elsewhere in the structure.

Energy requirements are met when the sum of energy absorbing components equals or exceeds the design energy. The energy absorbing components considered are the ship's hull deformation caused by the beam reaction, the marine fender deformation, the beam elastic strain energy, the sheet pile cell deformation and the hinge rotation from the development of plastic hinges.

Marine fenders were sized to allow adequate displacement to absorb energy, yet minimize beam moments. A combination of two fender sizes was found adequate to meet these requirements.

The distribution beam plastic hinge capacity was determined by selecting reinforcing bars patterns that provide large moment capacities for the section. Although the reinforcing steel percentage is very high it was accepted because of the anticipated infrequency of the collision design loading.

The dolphin structure was modeled to reflect the three-dimensional nature of both the structure and the loadings. Reactions from the distribution beam analysis, both along the channel and normal to the channel as well as gravity loads, were applied to the dolphins. Batter piles and struts were designed for biaxial bending such that yield may occur under imparted design ship energy.

As mentioned before, the timber fendering was designed so that the timber piles are the "weak link". Timber piles are capable of absorbing a relatively small amount of energy before failure, thus the failure loads were used for design of the timber system.

2. CONSTRUCTION

Construction of the pier protection system will be completed in two phases. The first phase will provide protection to the west pier of the swing bridge and minimal protection to the east pier. The second phase will complete the pier protection system at the east pier of the bridge.

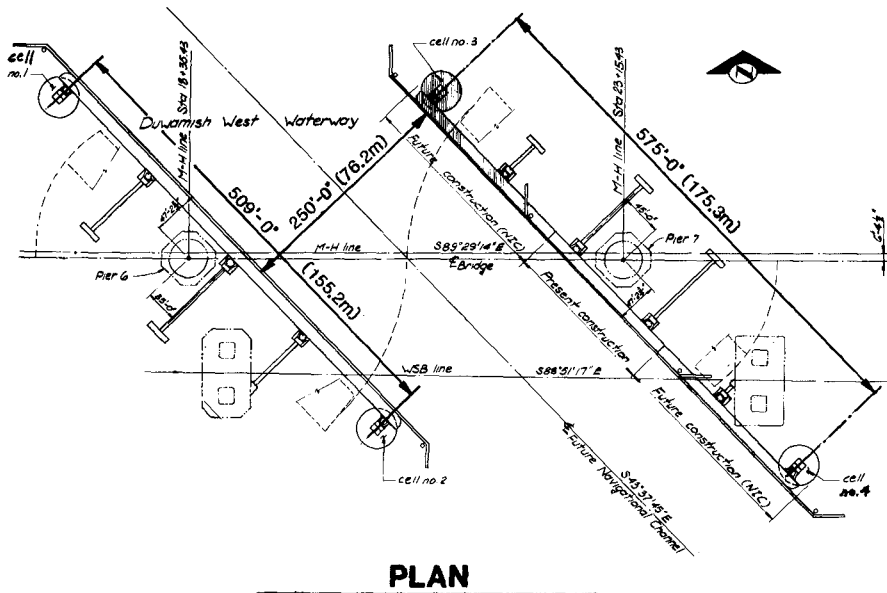

PLAN

Figure 1

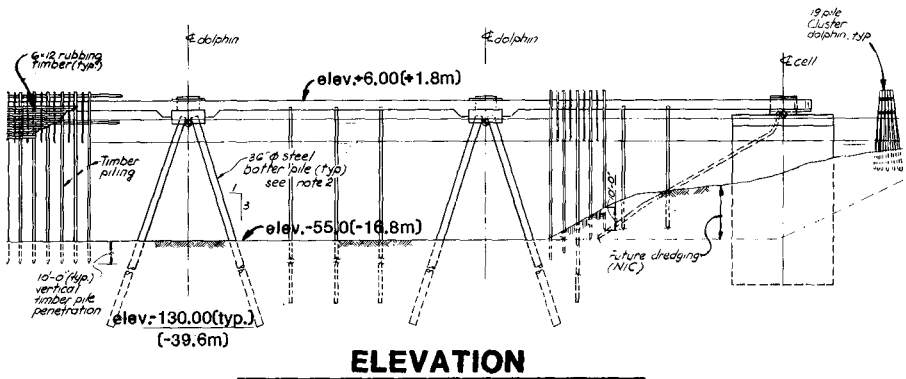

ELEVATION

Figure 2

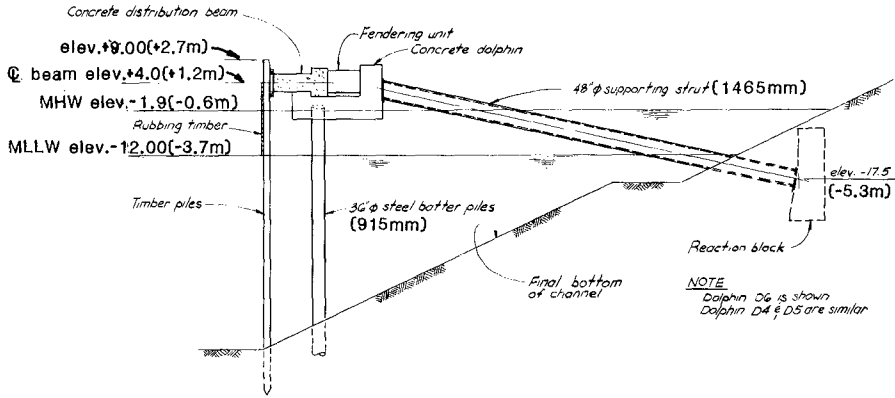

SECTION

Figure 3

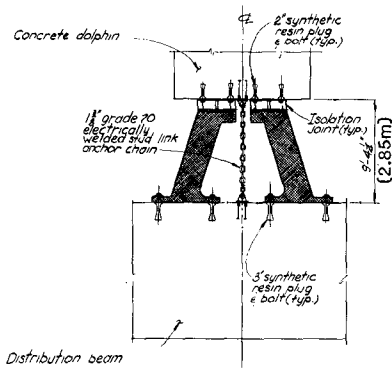

CORNER FENDERING UNIT

Figure 4

3. ACKNOWLEDGEMENTS

Owner of the facility is the City of Seattle. Project Engineer for the City is F. S. Yamagimachi.

Consulting services are provided by a Joint Venture of Anderson-Bjornstad-Kane-Jacobs (ABJK), Parsons Brinckerhoff (PB), and Tudor Engineering Company (TEC).

Project Manager for the Joint Venture is T. A. Kane (ABKJ).
Project Manager for PB is R. J. Berg.
Project Engineer for PB is H. Saxer.

The author was in charge of the design of the pier protection system and T. B. Jackson of PB prepared the detailed structural design calculations.

4. REFERENCES

1. Chapter 7, "Dynamics of Ship Collision" (Figure 7 on Page 46), Published in "Marine Board Report on Ship Collisions with Bridges," November, 1983.
2. Derucher, F.N. and Heins, C.P., Jr., "Bridges and Pier Proective Systems and Devices," [Chapter IV, "Design Parameters," pages 92 and 93 Hydrodynamic Coefficients.] Published by Marcel Dekker, Inc., 1979.
3. Kuesel, T.R., "Newport Bridge Collision," International Association for Bridge and Structural Engineering (IABSE) Colloquium. Copenhagen, 1983.
4. Larsen, J., "Ship Impact in Ferry Berths," IABSE Colloquium. Copenhagen, 1983.
5. Quinn, A. DeF., "Design and Construction of Ports and Marine Structures," (pages 330 to 393). McGraw-Hill, 1972.