

CHAPTER 214

SHORE PROTECTION OF KAOHSIUNG HARBOR OUTER BREAKWATER

Kuo, Shih-Duenn *

ABSTRACT

As shown in Fig.1 the main fairway of Port of Kaohsiung is running from north to south with a length of 12 kilometers. To the west, there is a sand bar served as a natural breakwater, the so called outer Breakwater, to provide the port and resident's property the necessary safety and security. Recently, due to rapid growth of container traffic and bulk cargo transportation, Port of Kaohsiung has developed some parts of the outer breakwater near the 2nd Harbor Entrance as Container Terminal No.4 with seven 14-meter-deep, 320-meter-long container berths and about 100 hectares container yard on northern side, and coal Terminal with 16-meter-deep, 320-meter-long berth and a huge storage yard on southern side. Therefore, the shore protection along the area become more and more important year by year. So far, some 6-kilometer seawall and 20 groynes have built successively, and already played a very important role for the shore protection there.

INTRODUCTION

Port of Kaohsiung is the largest port in Taiwan, R.O.C. and handles more than two-thirds of the Island's total imports and exports, over 100 million tons of cargo annually. It is expected to become one of the top international seaports in the world in terms of freight handled and physical size resulting from the huge expansion projects which have completed, now under construction or in planning stage.

Starting from 1967, Port of Kaohsiung come to a new era due to the construction of 2nd Harbor Entrance to navigate ships under 100,000 D.W.T. and to bring city of Kaohsiung to a international industrial metropolis. Since then, the outer breakwater between 1st Harbor Entrance and 2nd Harbor Entrance has been isolated. It not only influenced the development of the bar area, but also affected the stability of the shore line. Anyway, no protection is done until a blue-print for developing that area was made in 1970's by the Harbor Bureau to meet the overall expansion project of the whole harbor area. Further, following the completion of Cross Harbor Tunnel in 1984 to pave the way for the transportation between city of Kaohsiung and the island, the pace of development of the bar area, including construction of Container Terminal No.4 and seawall or groynes, is accelerated. So far, all projects go on well and in good performance, As a result, its container

* Senior Civil Engineer & Section Chief of Engineering Affairs of
Engineering Dept, Kaohsiung Harbor Bureau, Taiwan, R. O. C.

throughput of about 2.8 million TEUs in 1987 has put Port of Kaohsiung in third place in the world. This tremendous achievement is, no doubt, attributed to the perfect shore protection of the outer breakwater.

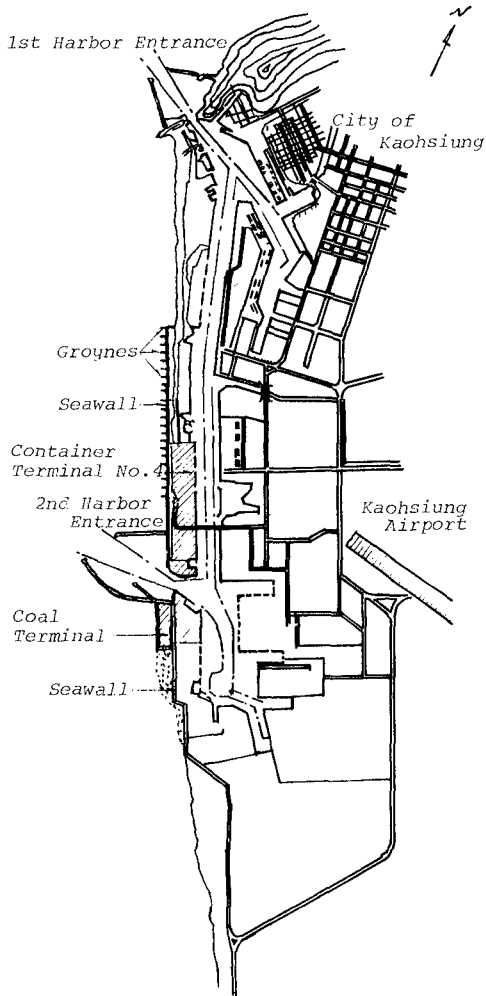

Fig. 1 Port of Kaohsiung

NATURAL CONDITIONS

(1) Sea bed condition:

The sea bed condition off the sand bar is very flat and homogeneous. Most of the 12 kilometers coastal area is distributed with fine sand of $D_m=0.15m/m$, and in a slope ranging from 1:30 to 1:100, as shown in Fig.2

except section F5 which located near 2nd Harbor Entrance has D_m value of about 0.30-0.35m/m at depth of 15m-20m, (see Fig.3).

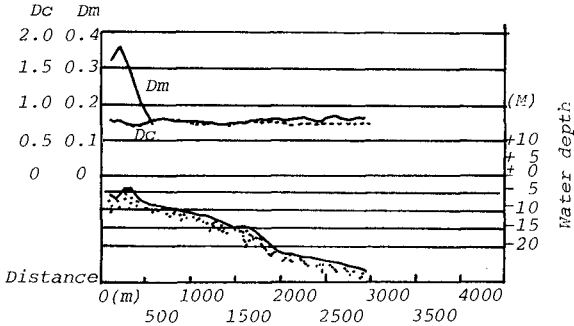

Fig. 2 Typical section of sand size VS sea bed gradient

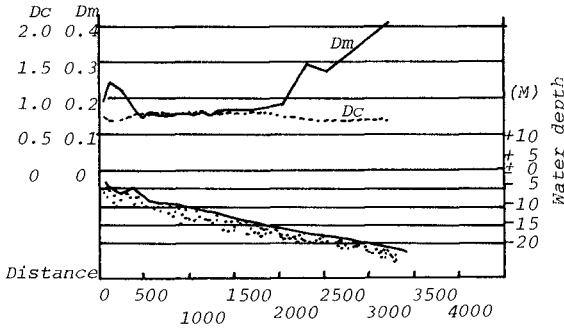

Fig.3 F5 section

(2) Wind condition:

Due to different paths of typhoon and different seasons of monsoon, the transport of sediment along the sea shore will be changed for different periods.

- a) Every year, typhoon (cyclone) from May through October occasionally packs wind of 11-65 m/sec to hit the area and to cause a lot of sediment transport along the coastal area. Among the paths which are probable to pass the area, path D is the main one to influence the coast area as shown in Fig.4 due to its big wave height & high wind velocity. Fig.5 shows the actual example of typhoon path D and its corresponding wave height and wind velocity.
- b) Winter monsoon, appearing mostly in NNE, N, NNW directions with wind speed of about 0.3-10 m/sec, is longer in duration, but less in unit sediment transport, as shown in Fig.6.
- c) Summer monsoon, prevailing in SE, SSE, S directions with 5.5-13.8 m/sec wind speed, performed in a different way as winter monsoon does (see the same figure as b.)

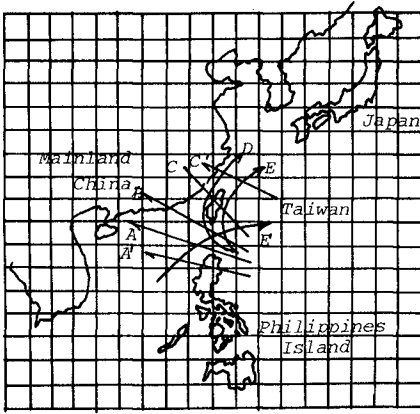

Fig. 4. Typical typhoon paths hitting taiwan area.

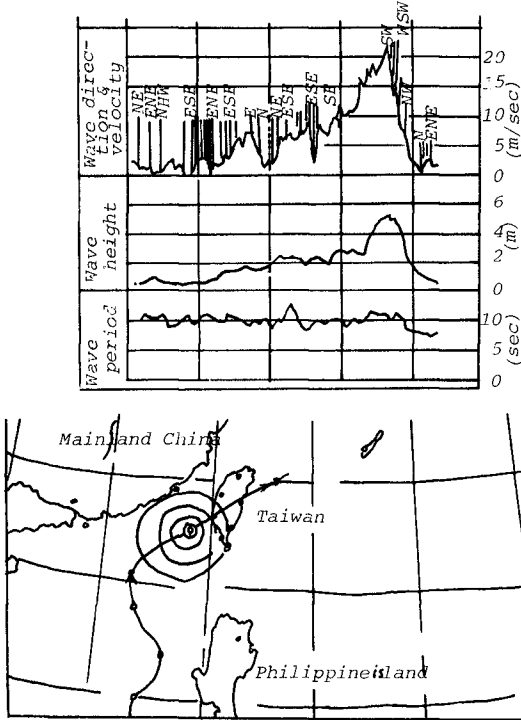

Fig. 5. Winds & waves for judy typhoon in May 30, 1966.

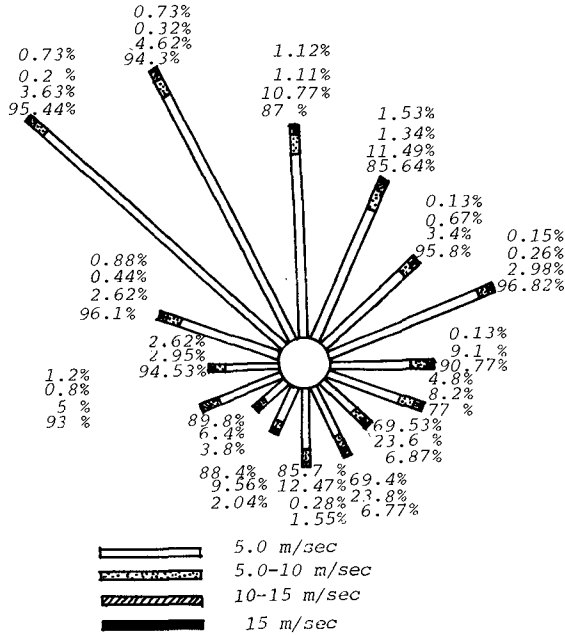

Fig. 6. Typical wind rose for Kaohsiung Harbor outer breakwater area

(3) Wave condition:

The wave condition in the area will depend largely on the magnitude and duration of typhoon and monsoon. A statistical wave data is shown in Table. 1. The max. wave height is some thing like 5-6 meters in 12 years from 1966-1977. while the corresponding max. significant wave height is about 4 meter.

Year	1966	1967	1968	1969	1970	1971	1972	1973	1974	1975	1976	1977	
Wave direction (S.W.)	63	56	53	50	48	49	47	49	50	52	55	57	
Max. wave	Wave height (M)	7.00	3.13	6.96	5.30	4.20	4.60	4.31	9.09	6.00	8.50	5.10	6.80
	Mean (M)	2.54	1.52	2.90	2.64	2.64	3.05	2.95	3.63	3.11	2.70	1.60	2.90
	Period (sec)	7.4	8.1	11.0	9.5	7.7	9.4	10.2	8.1	9.0	8.6	8.11	11.0
Sig. wave	Wave height (M)	5.24	1.67	4.95	3.70	2.04	3.85	2.96	6.29	4.01	6.40	3.10	4.10
	Mean (M)	1.71	0.99	1.75	3.09	1.51	1.98	2.95	2.78	3.90	2.98	1.90	1.71
	Period (sec)	7.7	8.5	9.3	10.8	7.8	5.7	10.5	8.8	10.1	8.3	8.4	10.0

Table. 1. Max. wave height and significant W. H.

(4) Others:

Such as tide, current etc. will also play an important factor to the shore protection. Tide in the area is about 0.7 meter in range as shown in Table. 2 and current is about 0.25 m/sec or 0.5 knots (nautical mile). But it will be changed depending on the wave height.

YEAR TIDE	1966	1967	1968	1969	1970	1971	1972	1973	1974	1975	1976	1977	M.V.
H.H.W.L.	1.60	1.55	1.75	2.60	1.53	1.60	1.63	1.62	1.60	1.51	1.56	1.56	1.60
L.L.W.L.	2.02	0.04	0.03	0.02	0.06	0.05	0.16	0.10	0.15	0.10	0.13	0.02	0.03
M.H.W.L.	1.09	1.14	1.10	1.11	1.16	1.11	1.12	1.13	1.14	1.15	1.14	1.16	1.15
M.L.W.L.	0.37	0.42	0.39	0.41	0.42	0.41	0.42	0.42	0.44	0.46	0.49	0.53	0.49
M.S.L.	0.69	0.74	0.71	0.71	0.76	0.73	0.75	0.74	0.76	0.77	0.78	0.78	0.76
H.W.O.S.T.	1.20	1.25	1.19	1.21	1.24	1.20	1.22	1.22	1.21	1.24	1.24	1.25	1.24
L.W.O.S.T.	0.32	0.40	0.32	0.35	0.37	0.36	0.38	0.37	0.39	0.41	0.47	0.49	0.43
H.W.O.N.T.	0.94	0.99	0.99	0.98	1.05	1.02	1.02	1.04	1.05	1.05	1.03	1.00	1.01
L.W.O.N.T.	0.42	0.44	0.44	0.44	0.47	0.47	0.48	0.48	0.49	0.51	0.54	0.56	0.51
Sprang Tide Range	0.89	0.85	0.88	0.86	0.87	0.84	0.84	0.85	0.82	0.81	0.75	0.78	0.81
Neap Tide Range	0.54	0.55	0.55	0.55	0.58	0.55	0.54	0.56	0.55	0.52	0.51	0.46	0.50
Mean Tide Range	0.72	0.71	0.70	0.70	0.73	0.70	0.70	0.71	0.70	0.69	0.67	0.63	0.66

Table. 2. Tide levels surveyed from 1966-1977

SEDIMENT TRANSPORT AND SHORE CHANGE

Through long term observation, the change of shore profile near 2nd Harbor Entrance is quite similar with the results of model test which carried out during construction of the 2nd Harbor Entrance.

- (1) Transport of sediment before construction of 2nd Harbor Entrance

- a) In winter season, sediment transport, from north to south, was governed by winter monsoon NNW, N, NNE. etc. and shore line appeared in an accretion condition along the whole area. While in summer, typhoon and summer monsoon SE, S, SSE etc. dominated the process of sediment transport, and shore line was eroded by the north-bound wave force (current). But finally the processes of accretion and erosion would come to balance, and return to its original state unless in abnormal condition such as being hit by super typhoon, and if so, the shore line would be scoured until next cycle. The contour line of water depth in the coastal area before 2nd Harbor Entrance being constructed is shown in Fig. 7.

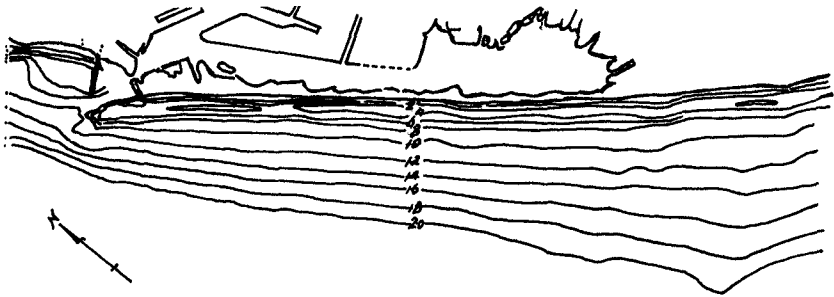

Fig. 7. Shore contours before construction of 2nd Harbor Entrance

- b) Due to the southern breakwater of 1st Harbor Entrance being constructed almost parallel to the shore line, the channel near the Entrance will be silted in summer time, and will be scoured in winter season, as shown in Fig. 8 and Fig. 9.

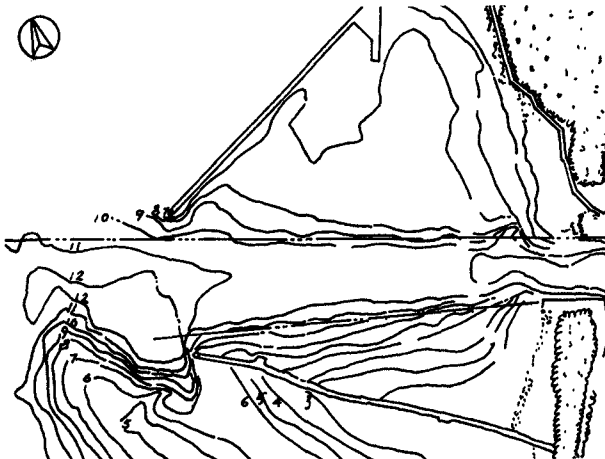

Fig. 8. Depth data of 1st Harbor Entrance surveyed in Sep-Dec. 1969

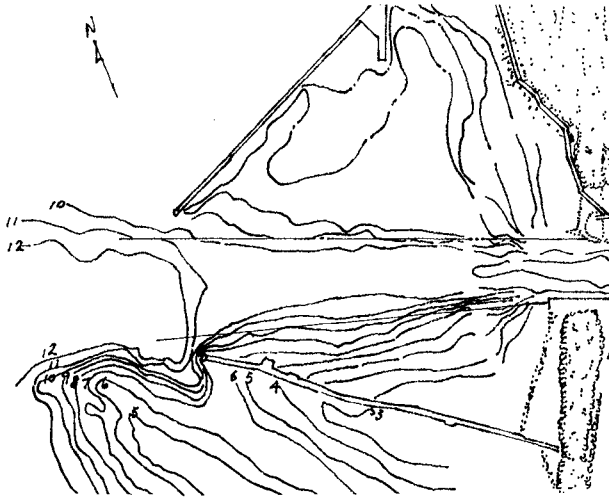

Fig. 9. Depth data of 1st Harbor Entrance surveyed in April-July 1970

(2) Transport of sediment after construction of 2nd Harbor Entrance:

Due to the prevention of the breakwater of 2nd Harbor Entrance, the change of shore line on both sides of the entrance has different result under the same conditions as described above, that is:

- a) In winter season, the northern shore of the entrance is a creative beach, while the southern shore is an erosive one, and vice versa in summer time. The contour line of water depth in the coastal area after 2nd Harbor Entrance being constructed is shown in Fig. 10.

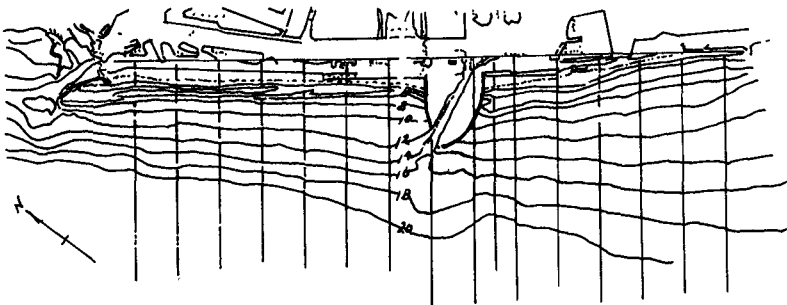

Fig. 10. Shore contours after construction of 2nd Harbor Entrance

- b) Due to the source of littoral drift being cut by the breakwater of 2nd Harbor Entrance, the shore line between 1st Entrance and 2nd Entrance may draw a sharp change toward the land area during typhoon season.
- c) Although, the channel of 1st Harbor Entrance is unable to totally free from silting or scouring, but it already has a great improvement to compare with the condition of which before construction of 2nd Harbor Entrance. It said from 50,000 m³/year decreasing to less than 10,000 m³/year.

PROTECTIVE METHOD

In addition to providing the port and residents the protective function, the outer breakwater of Kaohsiung Harbor is also to be considered as an integral part of port facility. Therefore, the protective facilities are designed as permanent structure as following.

(1) Parallel seawall:

Parallel seawall was built on the land area about 30 meters far from the shore line to parallel to the quay wall of container berth as a result of making up the required space of about 450m * 320m of back-up area in each berth to cope with the development of Container Terminal No.4 in northern side of the 2nd Harbor Entrance as shown in Fig. 1. In the south, the seawall was located about 300-meter off the shore line to constitute a big coal storage yard for the Coal Terminal, also shown in Fig. 1. So far, totally, some 6 kilometers of this seawall has been built to form the main structure for shore protection of the outer breakwater of Kaohsiung Harbor. For the seawall, besides the concrete parapet and wall itself, it also includes a earth dike planting with tropic trees to serve as a wind shield for the port area, and some side ditches to collect rainfall and overtopping salt water, if any, as shown in Fig. 11.

(2) Perpendicular groynes:

Perpendicular groynes, being constructed on every other 200 to 300 meter interval with each a length of about 90 meters, are perpendicular to the parallel seawall with a view to stabilizing the shore line and keeping the approach channel of the entrance from silting. In order to meet the attack of 6-meter height wave force, the groynes are designed as rubble mound type structure with 2 tons of modified Tetrapod for the armored layer as the conventional breakwater does, as shown in Fig. 12. From an engineer point of view, it sounds to cost too much, but for the point view of safety and security, it's worth-while to do so and perhaps it's the best choice for the long-range-project consideration.

(3) Artificial beach nourishment

In addition to the protective facilities mentioned above, the erosive beach between 1st and 2nd Entrances has been nourished with good material occasionally to prevent the shore from further scouring. From 1968 to 1982, the total spoil disposed to the area was about 34 million m³, But no headland is formed due to typhoon reason.

RESULT

Referring to the purpose as many other protective works do, the design of shore protective facility should take both direct function and indirect function into account, the former is aimed at protecting the shore and facility itself from eroding and damaging under the normal

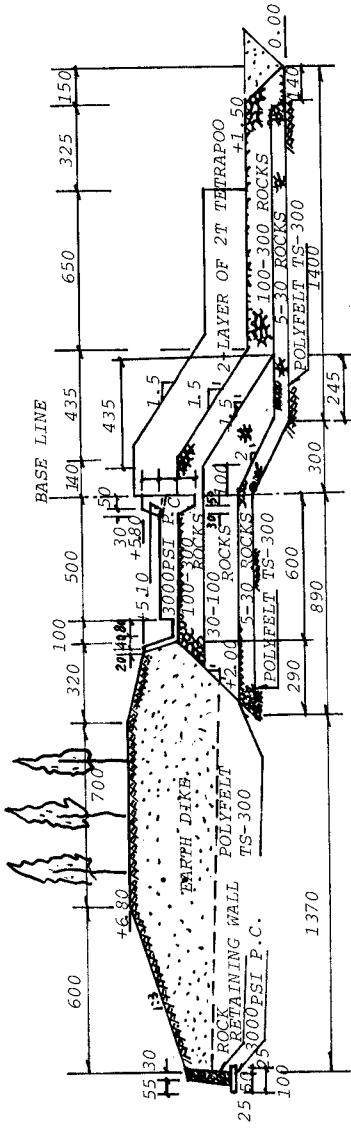

Fig. 11. Typical cross section of seawall

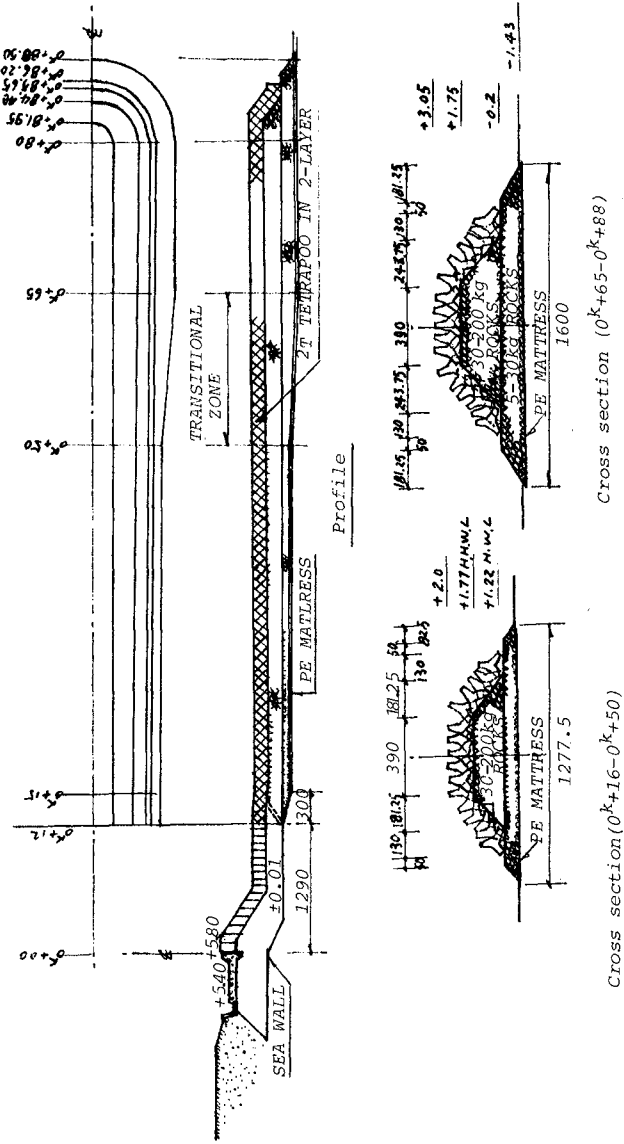

Fig. 12. Typical cross section & profile of groyne

condition. While the latter is emphasized on the function of durability from which the structure can still provide a retard action to decrease the loss to a minimum, should the facility once has been damaged in extraordinary conditions.

Basically, the protective facilities in Kaohsiung Harbor have followed the above-said guiding principle in design and construction. Therefore the shore protection of the outer breakwater has performed well up to now since its completion for about 13 years during which a number of big typhoons have experienced. Fig. 13. shows the field results of seawall & groynes and beach erosive conditions after being attacked by a great of big typhoons. Though, the seawall and groynes keep no damage at all, while the beach in between the groynes presents some different extend erosion due to different width(w) between the groynes and different length(L) of the groynes. Normally, for normal wave $w=4L$ is the best solution and for inclined wave, 35° - 50° against shore line, the best solution will be $w=3L$.



Fig. 13. Field results of shore protection of Kaohsiung Harbor outer breakwater

CONCLUSION

(1) For the protective structure, the rubblemound groyne (jetty) may be the most effective and reliable means in using against big wave force, should the layout and design method be right in principle. The case in Kaohsiung is a good example as the groyne built there have brought function into fully play up to now.

(2) The width between every two groynes is a main factor to beach control, it also means best result comes to perfect layout, from the field results got in Kaohsiung Harbor outer breakwater, we found that the width between every two groynes designing as 3 times and 4 times of the groyne length (length from shore line to head) for inclined wave (angle from 35° - 50° against shore line) and normal wave respectively, will be the solution for shore protection.

(3) Taking eroded beach into account, artificial beach nourishment is a very important approach to the shore protection. For instance, the northern shore of the 2nd entrance of Kaohsiung Harbor is something like an erosive beach for long term consideration, due to the source of sediment transport being cut by the breakwater. But, through artificial beach nourishment management, occasionally by disposing the good material of sand from channel dredging, the shore, however, has maintained in a stable condition year by year. It means that to the erosive shore line the best salution is to do beach nourishment and protective work simultaneously, if possible.

(4) Due to the breakwater of the 1st Entrance of Kaohsiung Harbor being laid in a way, almost, to parallel to the shore line, the channel near the Entrance was, frequently, to be silted by sand drift from the shore area between 1st and 2nd Entrance before shore protection in the area was done. While conditions have been improved since the completion of parallel seawall and perpendicular groynes. It means that shore protective management can play a multifunction role depending on what the case needs. The successful method in Kaohsiung Harbor, no doubt, has set a good example in this field.

(5) No headland or other simple methods can be used for shore protection like Kaohsiung Harbor outer Breakwater since it will resist the big wave up to 6-meter height and it left no tracks after disposing about 34 million M^3 spoil in the area in last 14 years from 1968-1982.

REFERENCES

- (1) Report on study of construction planning of Kaohsiung 2nd Harbor Entrance (1968), Kaohsiung 2nd Harbor Entrance Construction Department, Kaohsiung Harbor Bureau.
- (2) Gong. C. I. et all (1976), Report on Improvement study of Kaohsiung 1st Harbor Entrance.

*Listing of key words to index the paper entitled SHORE PROTECTION OF
OF KAOHSIUNG HARBOR OUTER BREAKWATER is:*

Kuo, Shih-Duenn,